



INITIAL SET UP

A. UNPACKING

Remove all plastic film, cardboard and tape from the outside of the vendor. Loosen any shipping devices used to secure interior parts during shipment (backspacer, shims or spacers).

To remove shipping boards from base, raise vendor on a well stabilized lifting device. Remove the leveling bolt which hold the boards in place and remove the boards. Replace bolts to equal heights in the threaded holes.

Another method to remove shipping boards is to split the boards apart. Using a pinch bar, or a heavy screwdriver and hammer, insert tool into the slots and force the board apart.

B. POSITIONING AND LEVELING

IMPORTANT: Place the vendor (in desired location) at least 3 to 4 inches away from any rear obstruction. This is for proper air flow through the refrigeration compartment. The system requires front to rear air circulation for proper operation. Level vendor with leveling bolts. Be sure all four leveling bolts are supporting the machine.

C. POWER SUPPLY CONNECTION

CAUTION: DO NOT USE AN EXTENSION CORD!

The Vendor's power requirements will vary depending upon the country it was purchased for. To verify the power requirements of the Vendor, check the serial plate located on the hinge side of the door (see figure 1 on page 3). The power requirements are listed on the serial plate.

To insure safe operation of the vendor, the vendor's power supply must be a properly grounded and polarized outlet. Before plugging the vendor into the outlet, test the outlet to confirm it will meet the vendors power requirements. If the power supply of the outlet is different from the power requirements of the vendor, a transformer may be necessary.

If the power requirements are not properly met, contact a licensed electrician and have the necessary correction made.

Should you require additional information contact a service representative, see parts, sales and service centers listed on page 13 and 14 of the machine installation and safety manual.

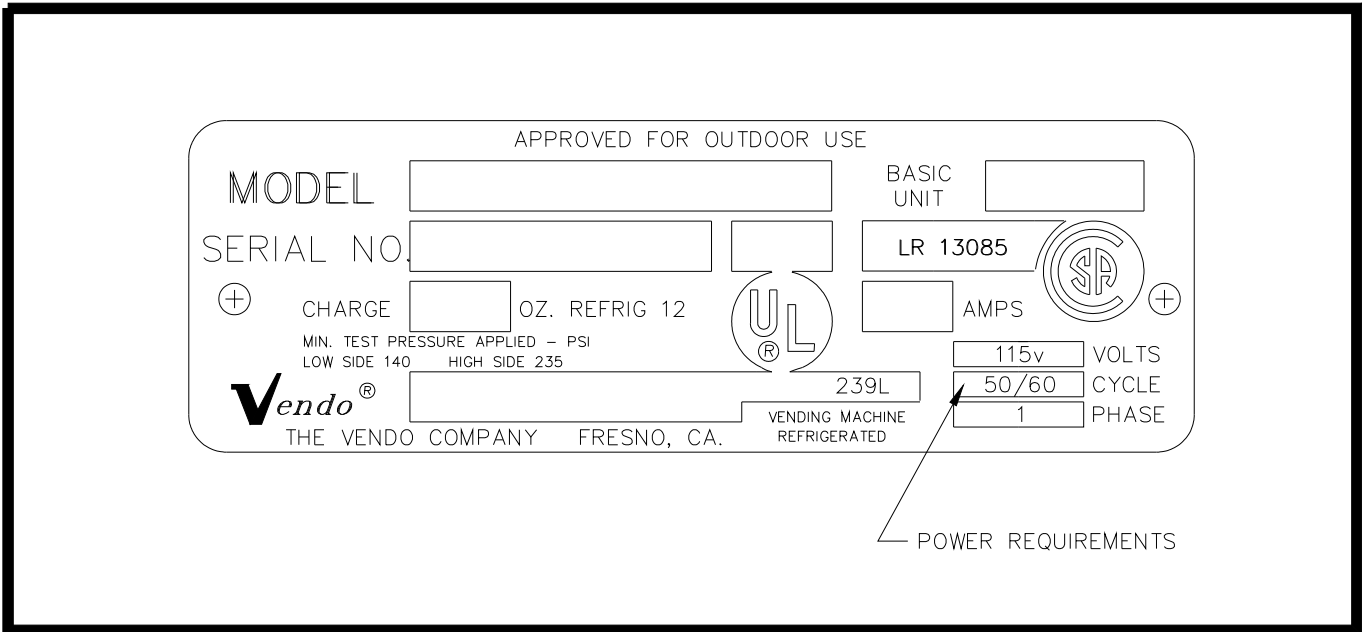

FIGURE 1

LOCK CODING

The safest method to code the lock is to remove it and secure it in a vise or similar tool. The lock can also be recoded in the handle.

(For the following steps refer to Figure 2)

STEP 1

Insert key into lock. Insert pin into hole in cap.

STEP 2:

To release cap, push pin in firmly and rotate key to right slot position. Remove cap and key as one unit.

STEP 3:

Using magnet end of loading tool, remove all seven tumblers.

STEP 4:

Slip preloaded coder on lock. Place loading tool into coder. Coder and tool will mount in one direction only. Press new tumblers firmly into place.

STEP 5:

Remove coder and tool as one unit. Check to insure that all tumblers are in place. Replace lock cap.

STEP 6:

Insert New key. Press cap in and rotate key counter clockwise left to locked position.

STEP 1

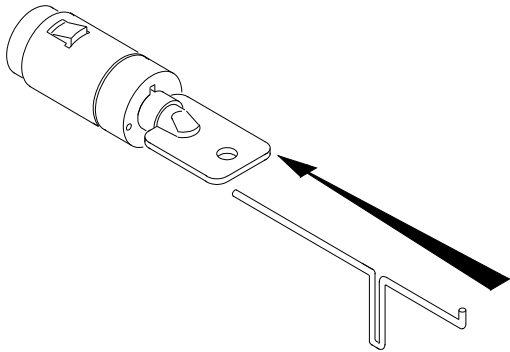

STEP 4

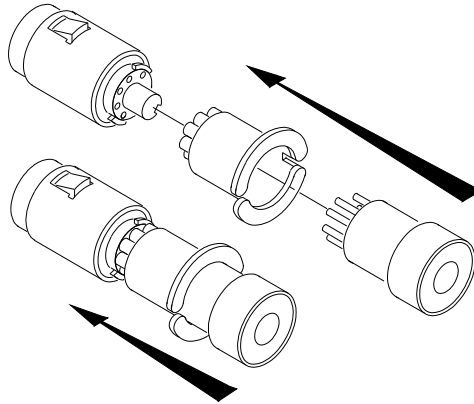

STEP 2

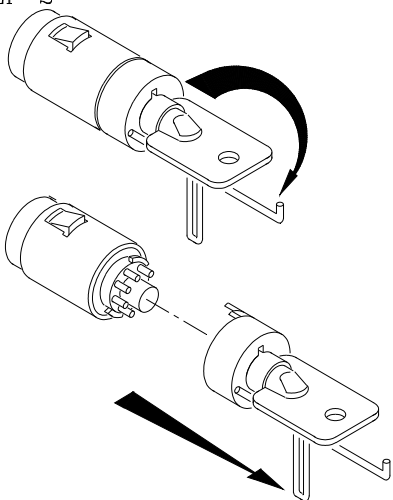

STEP 5

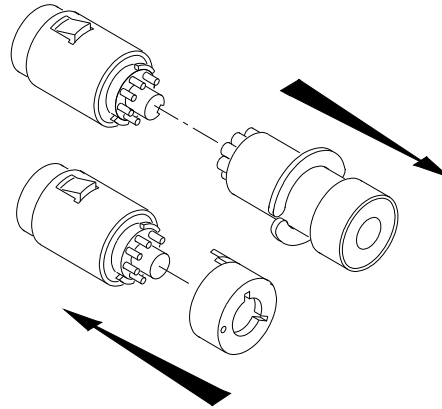

STEP 3

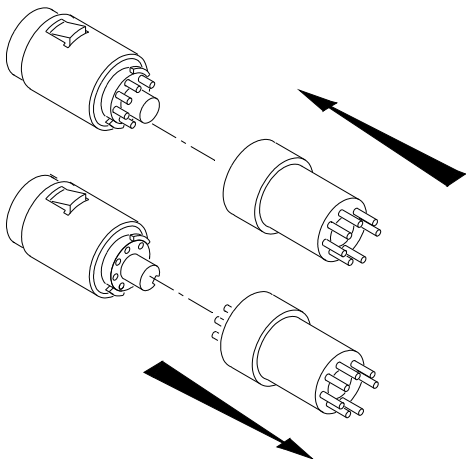

STEP 6

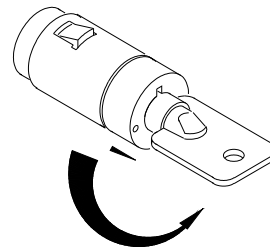

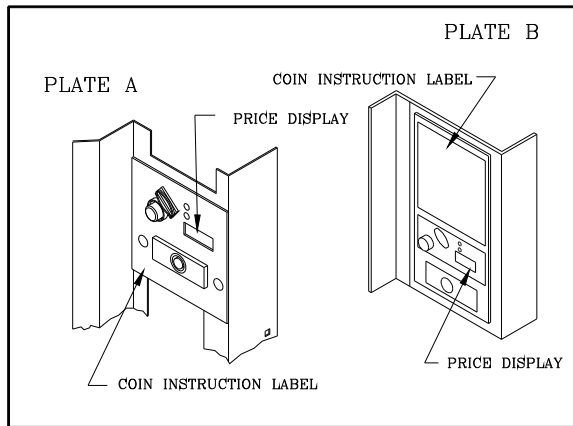

FIGURE 3

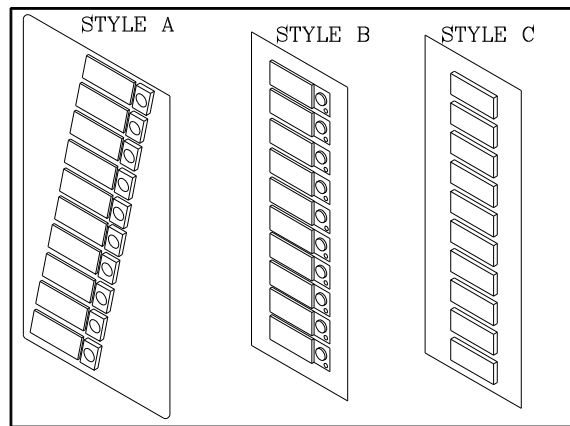

FIGURE 4

LABEL INSTALLATION

COIN INSTRUCTION LABEL & PRICE LABEL APPLICATION:

Apply labels to a clean and dry surface. Peel backing from label and apply to plate with a firm even pressure.

INSTRUCTION LABEL

(Refer to figure 3 for the following information.)

Plate "A" has Validator Opening separate and above the Coin Plate "B" shows the Validator Opening built in the Coin Plate. Apply Instruction Label to area shown (as needed by the vendor).

FLAVOR LABELS INSTALLATION:

In figures 4 & 5, corresponding styles are indicated by A, B, C, D, or E notations.

Insert Flavor Labels to the side or top of Selection Window or Button depending on the style. See Figure 4 for selection style. Rear view of windows and buttons is shown in Figure 5. Arrows point the direction to insert labels.

Selection Window and Selection Button Labels identify product contained in stack columns.

FIGURE 5

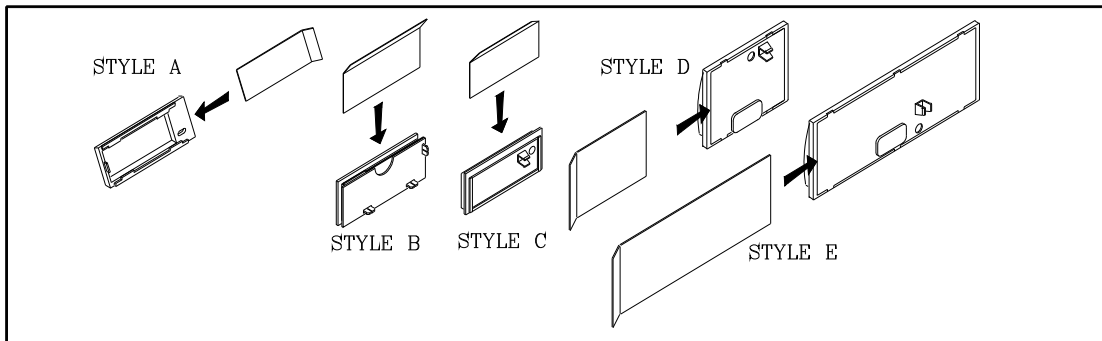

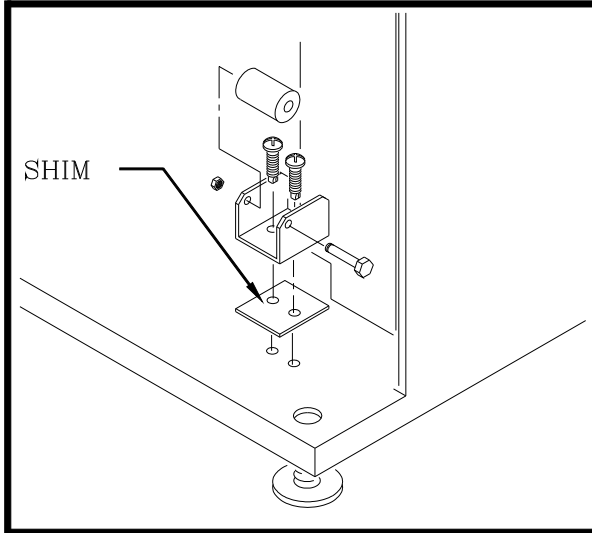

FIGURE 7

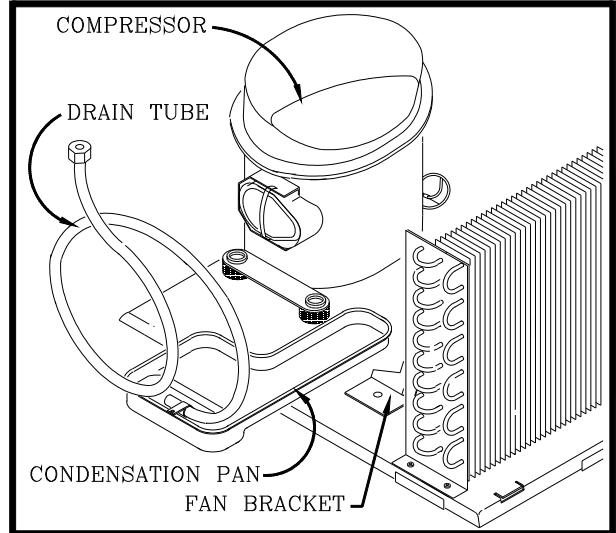

FIGURE 9

ALIGNMENT CHECKS

DOOR ROLLER CHECK:

The Door Roller assembly is raised or lowered by adding or removing shims, (see figure 7). Raising or lowering the roller will help ensure the proper alignment of the door lockstud to the cabinet latch.

DOOR ALIGNMENT CHECK:

After any door adjustment, the Quicker Lock should align itself automatically. If additional adjustment is necessary, loosen mounting screws, (see Figure 8), raise or lower latch to the correct position. Tighten mounting screws the floating nut of the Quicker Lock must be able to engage the bolt of the T-handle.

REFRIGERATION AREA CHECK:

Check the position of the Condensation Pan, see Figure 9. The correct position of the Condensation Pan is between the Compressor and the Condenser Fan Bracket. Be sure the Drain tube is clipped to the pan and free of kinks. A loop must be maintained in the tubing. The loop prevents warm air from reaching the evaporator area.

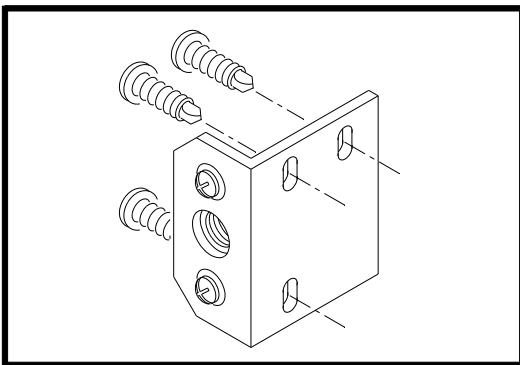

FIGURE 8



TEMPERATURE CONTROL

PRODUCT TEMPERATURE CHECK: (Reference only)

Allow vendor to run 24 hours. Vend product, insert test device (thermometer) into beverage.

TEMPERATURE CONTROL SETTING:

The temperature inside the cabinet is regulated by the Temperature Control, located on the left side of the Evaporator (see Figure 10). Before adjusting control, make sure the refrigeration system is working properly. Check that all fans run freely and do not make excessive noise. Check that the vanes of the Evaporator are free of obstructions. Air flow over the vanes is important for proper operation of the refrigeration unit. Check the door for a tight seal.

When the air temperature at the Capillary tube reaches 39 degrees Fahrenheit, the refrigeration system will cycle on (see Figure 11). To decrease the temperature, turn the Temperature Control Screw clockwise (see Figure 10). To increase the temperature, turn the screw counter-clockwise. The temperature will change approximately 6 degrees with every 1/4 turn of the control screw.

The Capillary tube is positioned in the air flow of the evaporator (see Figure 11). It must not touch the rear of the cabinet wall or the evaporator shield (except at the clip). It is possible to distort the position of the tube upon replacement and installation. If the refrigeration system is replaced, check the Capillary tube's position.

FIGURE 10

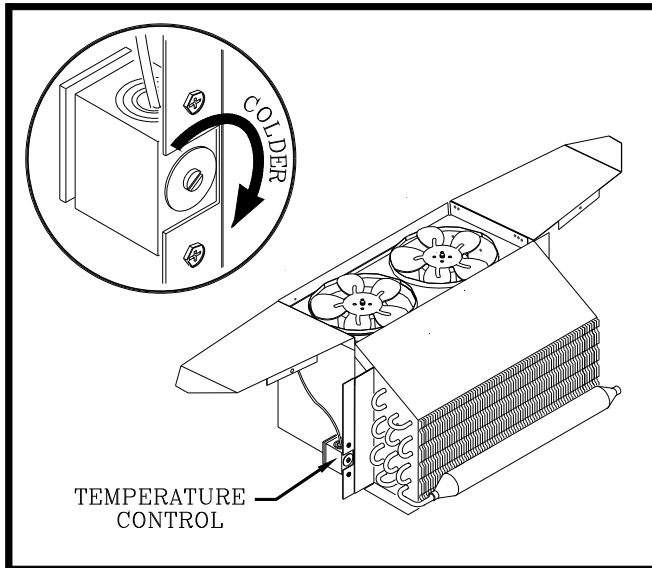
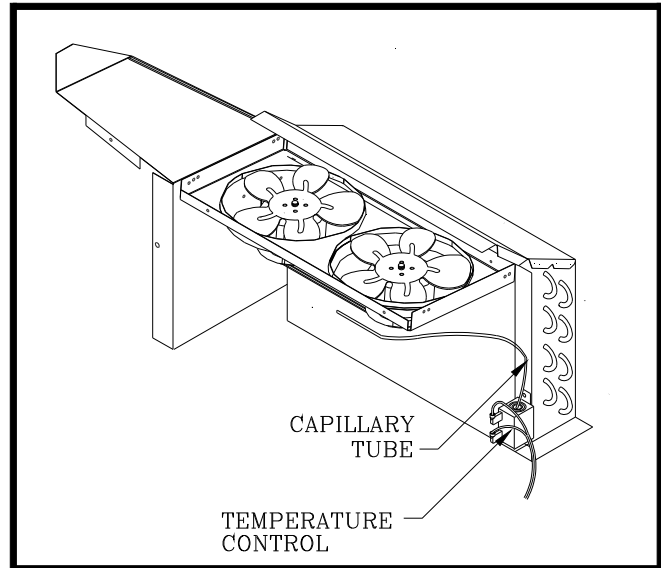

FIGURE 11





LOADING INSTRUCTIONS

BASIC LOAD SET-UP:

The Univendor-2 machine is capable of vending a variety of product. The Chart on page 7 is a basic guide for the load set-up of these products. Refer to the chart and the items in Figure 12 for each product's setting and kits. Installation Instruction are included with each kit. Call a service representative for kits or further information.

Open upper and lower product cage assemblies at front of stack to load product in columns. Load product evenly. Bottles are loaded with crown end placed toward the back of the column. After filling columns, close product cage assemblies. In initial loading, prime the machine by advancing the product into the buckets. To advance product, insert proper coins and push the selection button of the column you wish to prime. When the bucket is loaded the column is ready to vend. Prime all columns.

FIGURE 12

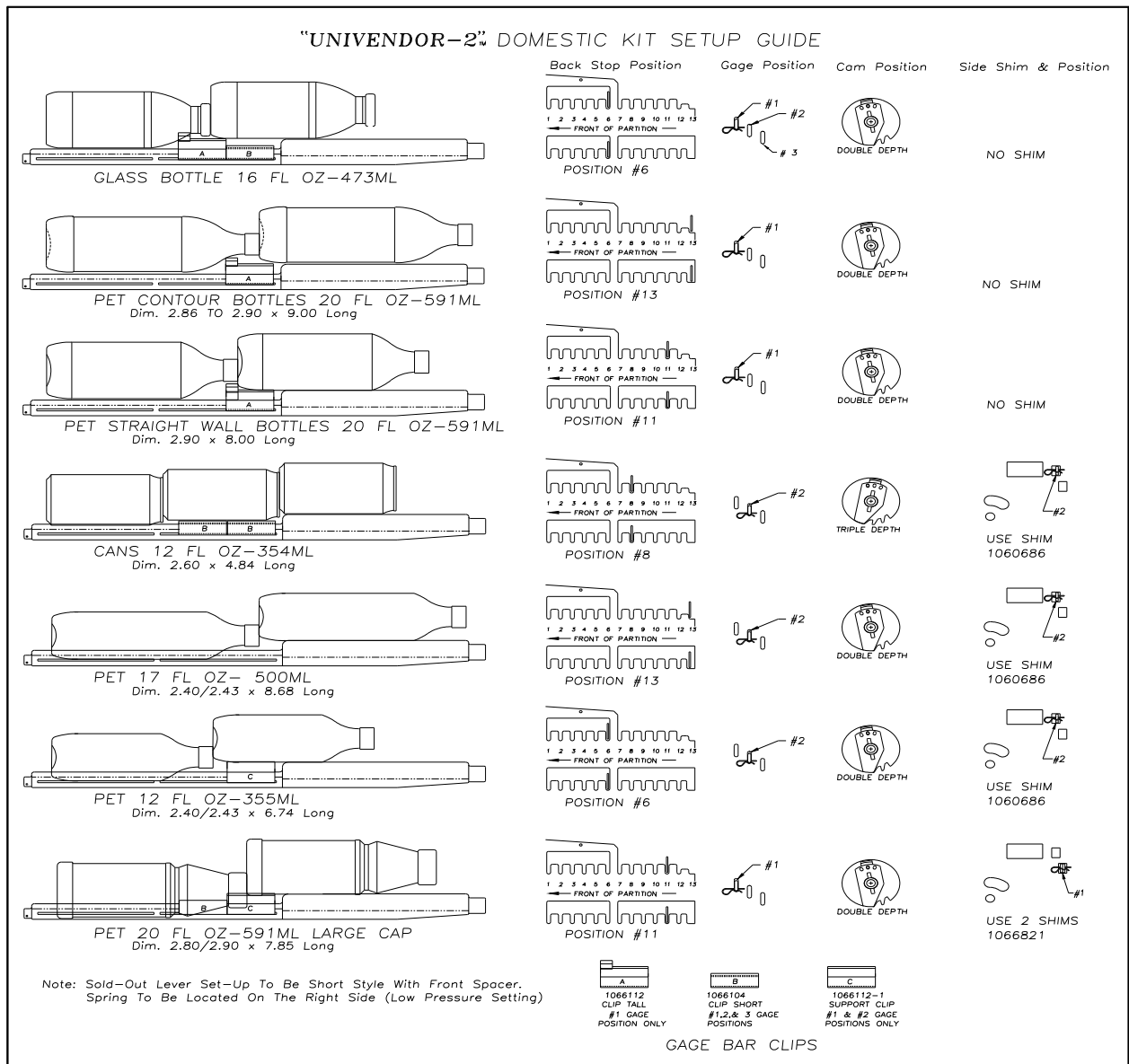



VEND MECHANISM PARTS DESCRIPTION

The parts listed below are part of the Vend Motor Mechanism (refer to Figure 17 on page A6). One Mechanism is required per column. The parts are interchangeable. Setting will differ between single, double or triple depth.

MOTOR: P/N 388637

This motor is a thermal protected, 115 volt, 60 hertz, shaded pole motor. The motor has an externally mounted spring loaded mechanical brake. The Motor is attached to the Mech. Plate by three screws.

MOTOR CAM: P/N 390360

The Motor Cam assembly consists of two parts, the Cam and the Cam Retainer. The Cam controls the Motor Carrier and the Start/Bypass Switches. The Cam is Attached to the Motor by the Cam Retainer (Retainer P/N 389401). The Retainer rotates left or right, provides for single, double, or triple depth operation. (see page S-7 for Cam Settings)

MOTOR CARRIER SWITCH: P/N 388687

Two switches are located below the Motor Cam. The outside switch is the motor carrier switch. This switch holds the motor on through the vend cycle. The motor stops when the motor Carrier switch drops out.

SOLDOUT SWITCH: P/N 368299 / BASE SWITCH: P/N 388303

There is one Soldout Switch and one Base Switch above the Vend motor. The Soldout Switch is actuated by the Soldout flap when the column is empty. It stops the motor from running. When all columns are empty the Electronic Control stops the coinage from accepting money.

SELECTION SWITCH: (See part Section of the Manual for P/Ns.)

The selection switch sends power to a Vend Motor when a Customer Presses a Selection Button. The Selection Switches are beneath the Selection Button/Windows.

VEND BUCKET: P/N 1060139

The Vend Bucket holds the product(s) in a ready to vend position at the base of each column.

ADAPTER COUPLING: P/N 1027042

The Adapter coupling couples the motor to the bucket. It is located behind the motor, on the motor shaft.

ANTI-TILT CLIP: P/N 389712

The Anti-Tilt Clip prevents product from dropping out of the Bucket if the Vendor is tilted. The Clip is located in the bucket.

GATE: P/N 1066082

The gate holds product above the Vend Bucket.

GATE LINK: P/N 1008501

The rotation of Vend Bucket moves the gate link, this opens the gate allowing one layer of product to drop into the bucket.

GAUGE BAR: P/N 1064333

The Gage Bar Holds the product (s) inside the bucket. It also regulates which product is vended first when Double or Triple depth setting are used (See page S-7 for setting).

FIGURE 13

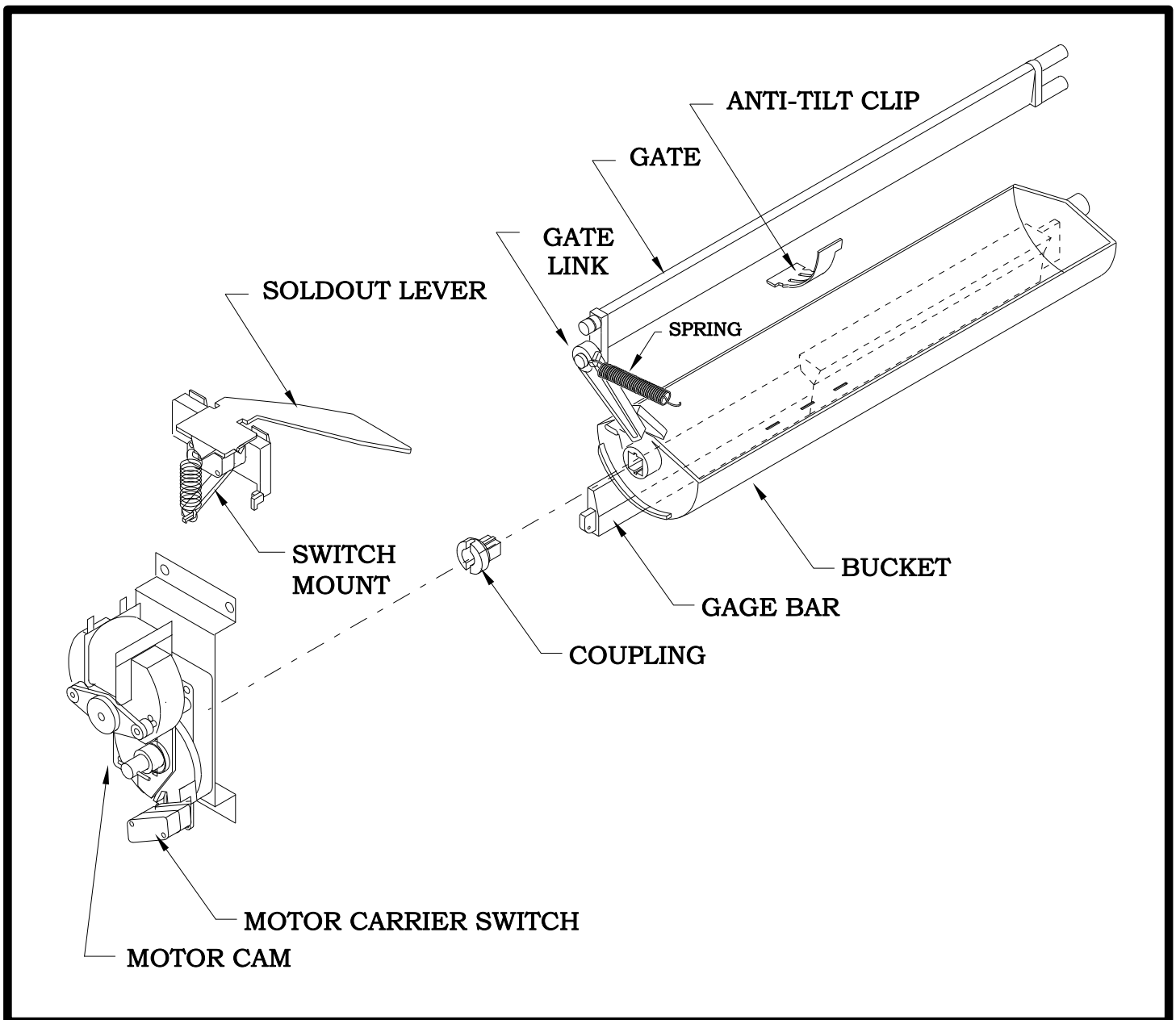

VEND CYCLE

Several operations take place during the Vend Cycle: a purchase is made, the cam and bucket rotate, product is dispensed and reloaded. The sequence of these operations change slightly when the column's depth setting is changed. With the Single Depth Setting, one purchase is made and the bucket is reloaded, the Cam Sequence occurs once per bucket revolution. With the Double Depth setting, two purchases are made before the Bucket is reloaded, the Cam Sequence occurs twice per bucket revolution. With Triple depth setting, three purchases are made.

PURCHASE SEQUENCE:

- PS 1. Customer insert money.
- PS 2. The Coinage Unit sends a signal energizing the Credit Relay. This creates a path of power for the Selection Switch.
- PS 3. Customer presses a Selection Button.
- PS 4. The chosen Selection Switch closes, creating a path of power to energize a Vend Motor.
- PS 5. The Vend Motor turns the Bucket and Cam.
- PS 6. Product is Immediately dispensed.

CAM SEQUENCE: (See Figure 14, Double depth Setting Pictured)

- CS 1. As the Motor turns the Cam, the Switch falls into the low part of the cam. This interrupts the power path to the Credit relay canceling credit.
- CS 2. Simultaneously, the Motor Carrier Switch is lifted to the high part of the cam. This provides an alternate path of power, to the Vend Motor.
- CS 3. With the Cam still rotating, the Switch lifts back to the part of the Cam, (permitting another purchase when it is required).
- CS 4. The Motor Carrier Switch falls into the lower part of the Cam, cutting power to the Motor. The Motor stops.

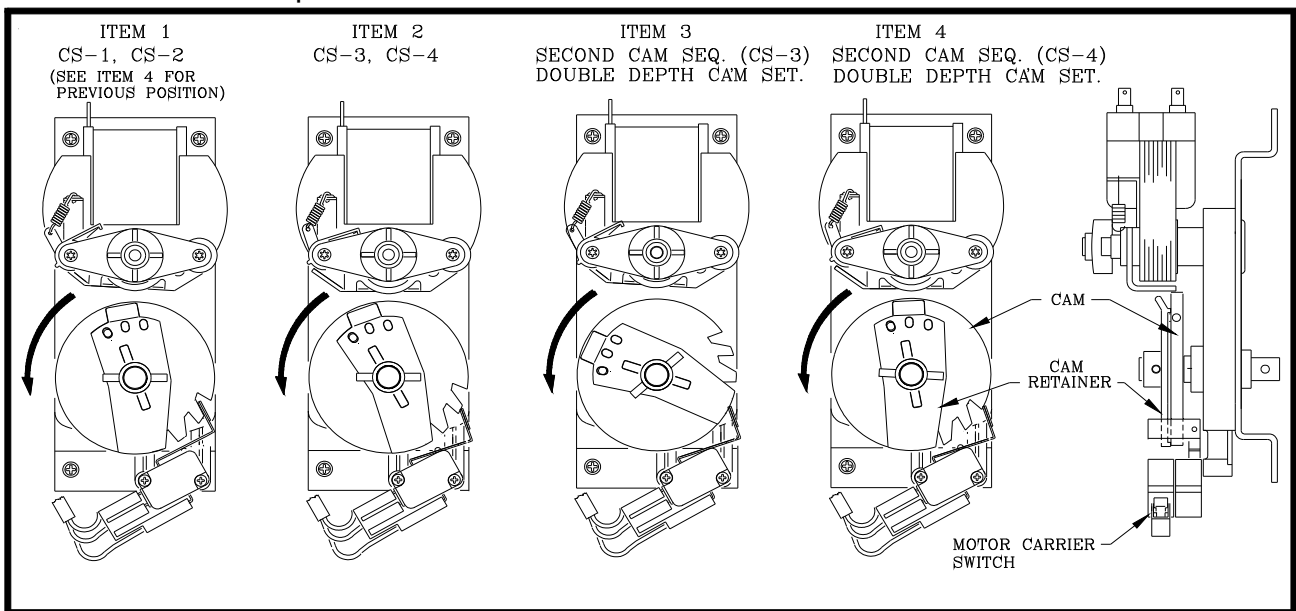
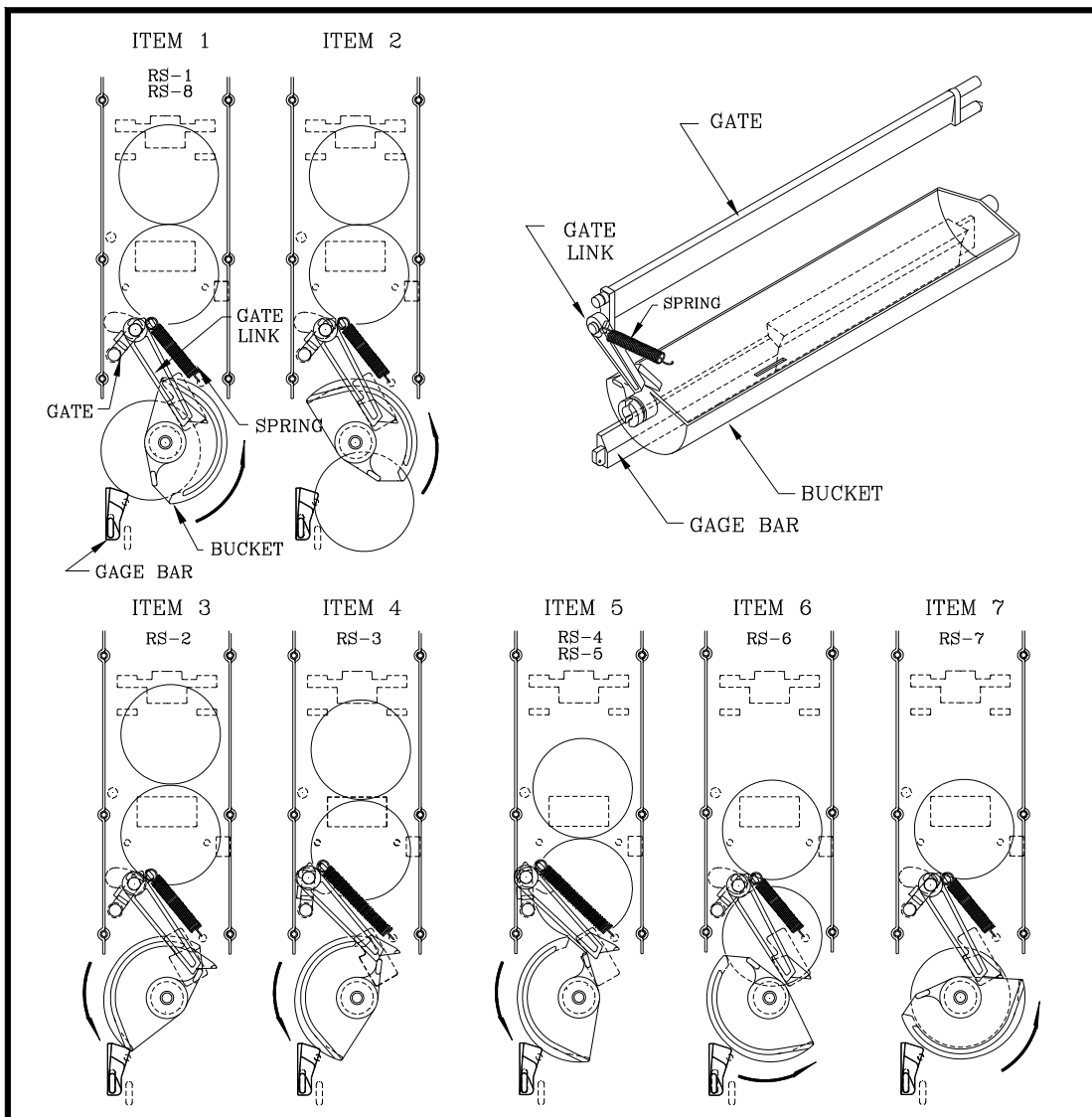

FIGURE 14

RELOADING SEQUENCE: (See Figure 15)

- RS 1. The gate link rests at a locked position, in a cutout on the mech. plate. This locked position prevents the gate from opening out of sequence.
- RS 2. The gate link is guided by a slot in the mech. plate and actuates by a ridge on the bucket. As the bucket turns, the link is moved out of the locked position.
- RS 3. As the link rises, the gate is opened. The spring maintains Pressure on the Link and the gate.
- RS 4. Product falls onto outside of the bucket.
- RS 5. The bucket releases the gate link causing the gate to rest against the product.
- RS 6. As the product falls into the bucket, the link returns to the locked position and the gate is closed.
- RS 7. The product remaining in the column is caught by the closed gate, keeping it above the bucket.
- RS 8. Bucket stops, product is Ready to vend.

FIGURE 15



LIGHTING WIRING DIAGRAMS

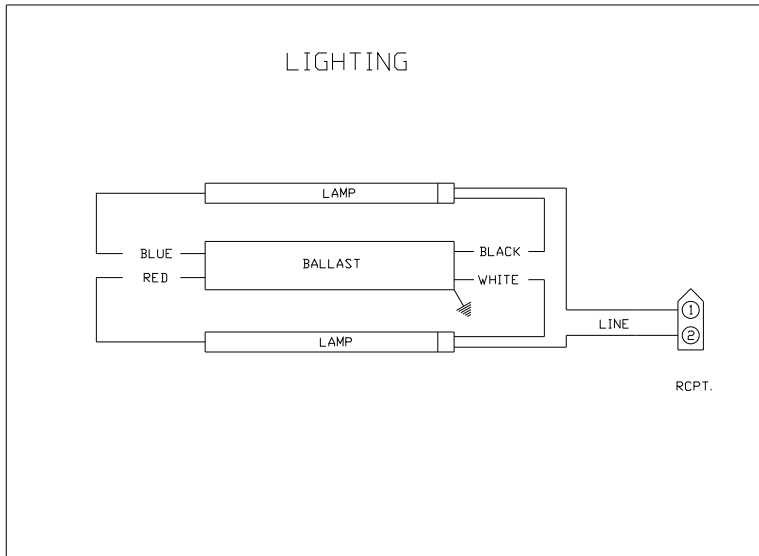

REFRIGERATION WIRING DIAGRAM

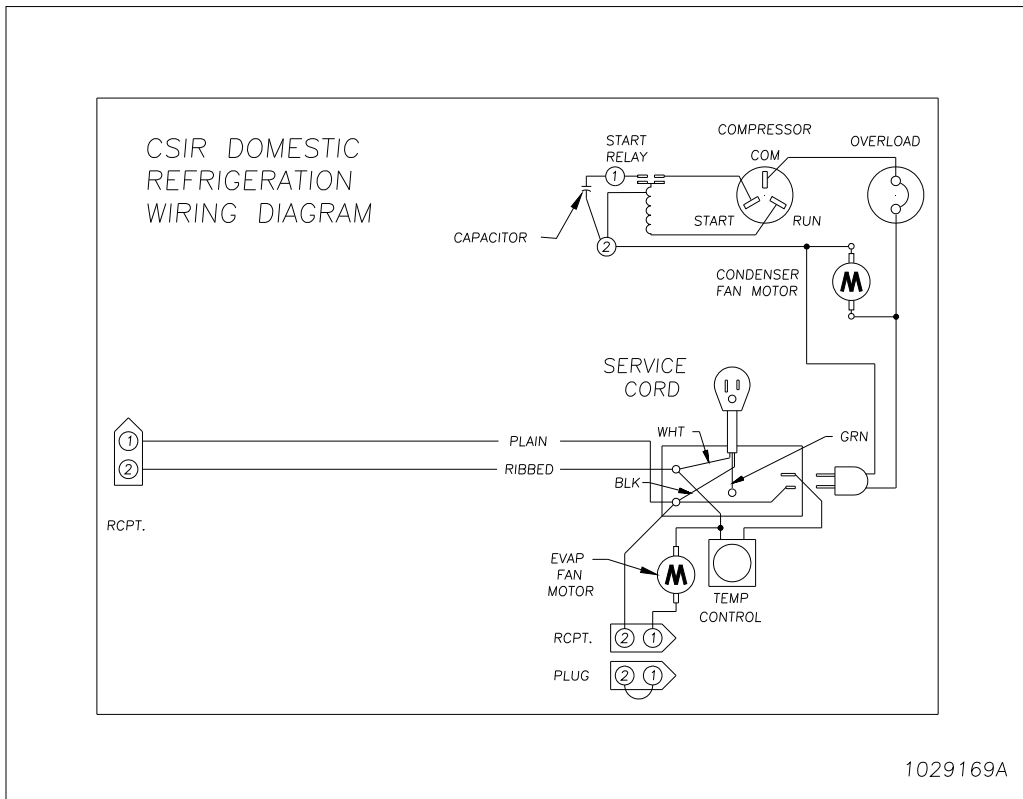



REFRIGERATION OPERATION

The refrigeration operation section is divided into three areas: Basic Refrigeration Principle, Detailed Vending machine Refrigeration cycle, and Parts Description.

BASIC REFRIGERATION PRINCIPLE

What a refrigeration system really accomplishes is the transfer of heat. A refrigeration system removes the excess heat from a refrigerated area and then transfers it to a condenser where it is dissipated. As heat is removed, the refrigerated area cools.

In vending machines, large quantities of the heat must be transferred rapidly, economically and efficiently. This process must be able to withstand continuous repetition, without loss of refrigerant, over an extended period. The most common system used in the vending industry is the vapor compression (or simple compression) cycle system. It consists of four basic elements: an evaporator, a compressor, a condenser, and a pressure reducing restricted (all part of a sealed system).

The compression system operates at two pressure levels: the low evaporating pressure and the high condensing pressure. The refrigerant acts as the transport medium, in which heat is moved from the evaporator to the condenser; at the condenser, the heat is dissipated into the surrounding air.

The liquid refrigerant changes from a liquid, to a vapor and back to a liquid again. This change of state allows the refrigerant to absorb, and rapidly discharge, large quantities of heat efficiently.

BASIC VAPOR COMPRESSION SYSTEM CYCLE DESCRIBED:

In the evaporator the liquid refrigerant vaporizes. This change occurs at a temperature enough to absorb heat from the refrigerated space. The temperature of vaporization is controlled by the pressure maintained in the evaporator (the higher the pressure, the higher the vaporization point).

The compressor pumps the vapor from the evaporator, through the suction line, and to the condenser. The compressor takes the low pressure vapor and compresses it, increasing both the pressure and the temperature. The compressor pumps the vapor at a rate rapid enough to maintain the ideal pressure. The hot high pressure vapor is forced out of the compressor, into the discharge line and then into the condenser.

Air is blown through the condenser, allowing heat to transfer from the condenser and into the passing air. As the heat is removed, the stored refrigerant is condensed into a liquid. The liquid refrigerant is stored in the lower tube of the condenser. It is there, available to flow through the restrictor tube, back into the evaporator, where the refrigeration cycle is repeated.



DETAILED REFRIGERATION CYCLE

The following is a detailed refrigeration cycle as it applies to the refrigeration system installed in Vendo equipment. (Refer to the flow chart in Figure 16)

As the temperature in the cabinet rises, the liquid in the thermostat feeler bulb also rises in temperature. As this liquid becomes warmer, it expands. This expanding liquid expands against the temperature control bellows which operates the temperature control switch. The temperature control switch turns on both the compressor and condenser fan.

The evaporator fan pulls air from the front of the refrigerated space of the cabinet. It pulls the air through the evaporator, and blows it up the back of the vend stack. (The evaporator fan runs continuously.) As the air passes through the evaporator, heat is drawn from the air and transferred to the liquid refrigerant. As the cooled air circulates through the vend stack, heat is drawn from the product and transferred to the circulating air. The heated air is again drawn through the evaporator where the heat is removed.

In the evaporator, the liquid refrigerant draws heat from the circulating air. As refrigerant receives heat, it vaporizes.

The compressor pumps the vapor from the evaporator and compresses it (increasing both pressure and temperature). The compressor forces the compressed vapor out, through the discharge line and into the condenser.

The condenser fan pulls air through the condenser. As the hot refrigerant vapor passes through the condenser tubes, heat is drawn from the vapor. This heat is dissipated into the passing air, the air then exits out the back of the vendor. As the refrigerant vapor in the condenser lines is cooled, it returns to a liquid state.

From the condenser the liquid flows to the drier. The drier removes any water and solid particles from the liquid refrigerant.

The cooled liquid refrigerant continues from the drier, through the capillary tube, to the evaporator. The capillary tube steadies the flow rate of the refrigerant. Its small inside diameter allows the pressure in the evaporator to remain low while the pressure in the condenser is high.

The cool refrigerant in the evaporator draws heat from the circulating air in the cabinet. As the temperature in the cabinet drops, the liquid in the thermostat feeler bulb cools and condenses. The condensed liquid releases the pressure against the thermostat control bellows, de-actuating the temperature control switch. The deactuated control switch turns off the compressor and condenser fan.

When the temperature in the cabinet rises above the thermostat's setting, the compressor and the condenser fan engage again. The refrigeration process is continuous as long as the compressor operates.

FIGURE 16

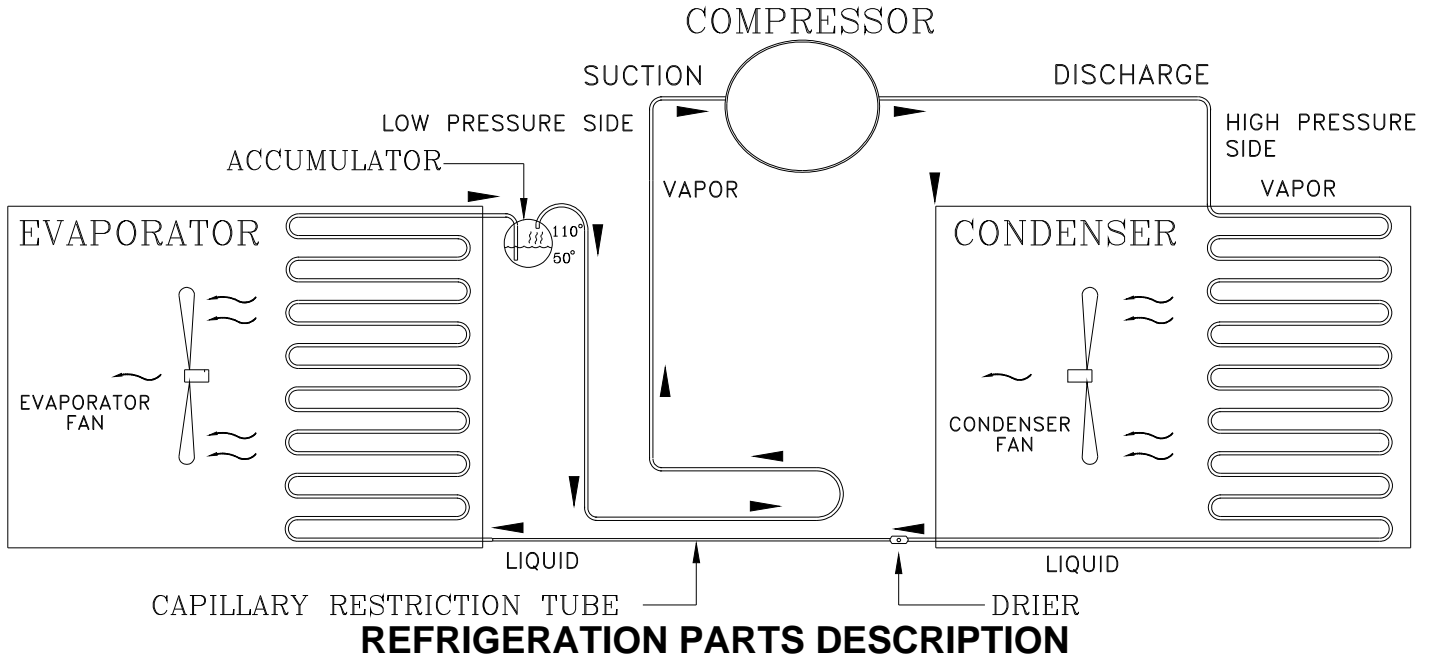

The Compressor, Condenser, Drier, Capillary Tube, Evaporator, and Accumulator are part of a sealed system (refer to figure 16). These items are not available separately. For the part number of the sealed refrigeration system refer to the common parts section of the manual.

COMPRESSOR

The compressor takes in low pressure vapor and compresses it, increasing both the pressure and the temperature. The hot high pressure gas is forced out to the condenser. The compressor and the motor that drives the compressor are sealed inside a housing. The compressor, as a unit, is mounted on the refrigeration base. The base is mounted in the bottom of the vendor, outside the sealed refrigeration space.

CONDENSER

The condenser takes heat out of the high pressure vapor that it receive from the compressor. As the vapor passes through the condenser it cools and returns to a liquid state. The condenser is mounted to the refrigeration base near the front of the vendor. It is easily accessible for cleaning.

DRIER

The Drier is a molecular sieve strainer drier. It removes water and solid particles from refrigerant liquid. One side of the dryer is connected to the outlet line of the condenser; the other side is connected to the capillary tube going to the evaporator.



REFRIGERATION PARTS DESCRIPTION (CONTINUED)

CAPILLARY TUBE

The capillary tube controls, at a steady rate, the flow of refrigerant liquid to the evaporator. It has a very small inside diameter to keep pressure in the evaporator low while the pressure in the condenser is high. It is the connecting link between the condenser and evaporator.

EVAPORATOR

The Evaporator is a heat transference device. It removes the heat from the air in a refrigerated space and transfers it to the refrigerant liquid. This liquid evaporates into a vapor and is sucked out by the compressor. The evaporator is mounted inside the refrigerated space of the cabinet, directly below the delivery chute.

ACCUMULATOR

The accumulator traps any refrigerant liquid which did not boil off into a vapor before reaching the compressor. The accumulator allows the refrigerant liquid to boil off as a vapor (preventing damage to compressor). It also prevents suction line sweating. The accumulator is mounted in the suction line on the outline side of the evaporator.

FIGURE 17

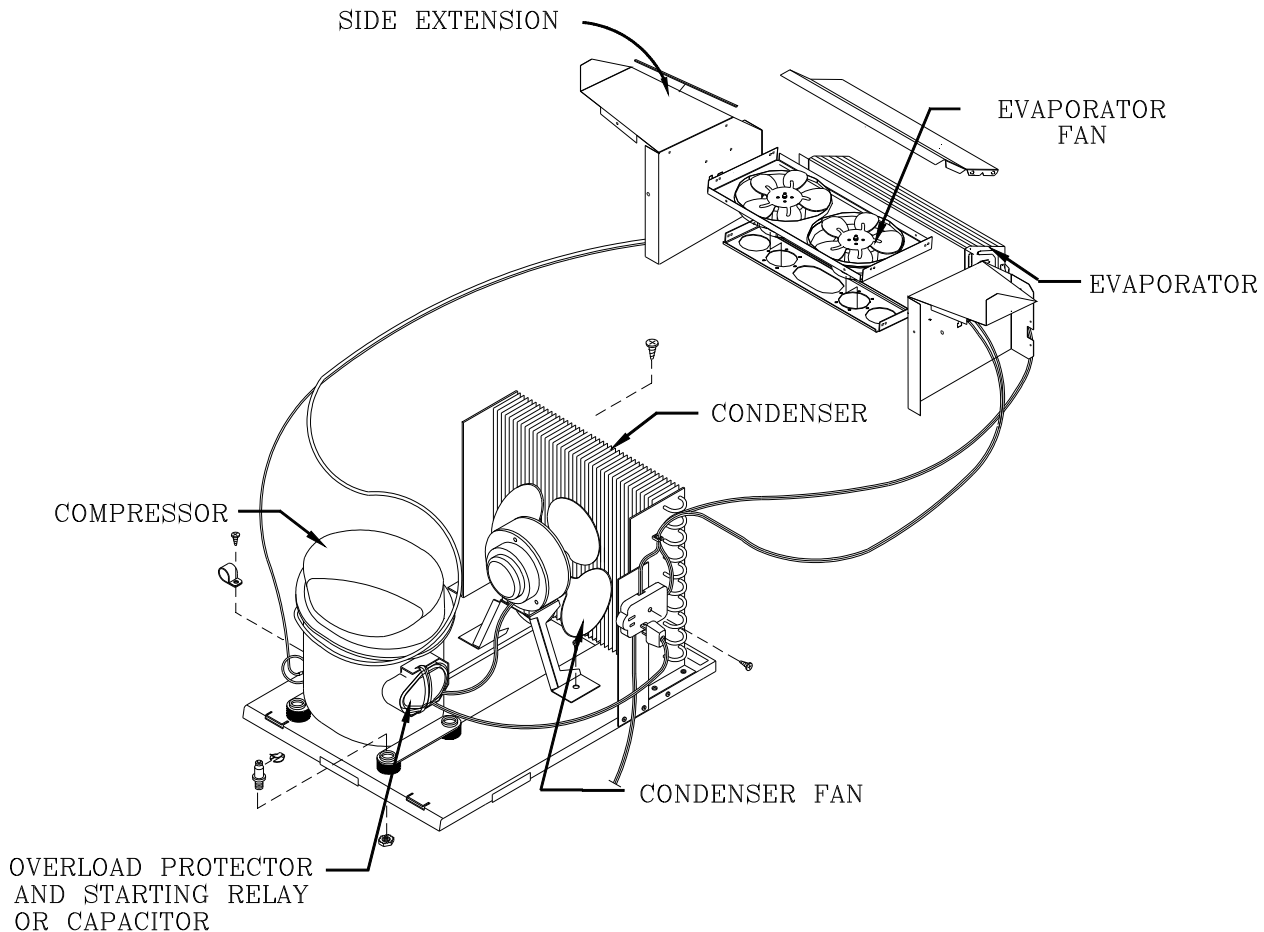



(The parts listed below are not part of the sealed refrigeration system and are available separately. For part numbers, see the refrigeration assembly in the common parts section of the manual.)

CONDENSER FAN ASSEMBLY

The condenser fan pulls cool air from outside the vendor, through the condenser, over the compressor and blows it out the back of the vendor. This cool air removes excess heat from refrigerant in the condenser. The condenser fan runs when the compressor is engaged. The fan assembly is mounted on the refrigeration base between the condenser and compressor.

EVAPORATOR FAN ASSEMBLY

The Evaporator fan pulls air from the front of the refrigerated space, through the evaporator, up the rear of the refrigerated space into the vend stack. The fan blows air through the evaporator (which removes the heat from the air). It circulates the cool air over the product, removing excess heat from the product. The evaporator fan assembly is mounted to a fan bracket, mounted to the extensions of the evaporator. These parts are located in the refrigerated area of the cabinet.

TEMPERATURE CONTROL

The temperature control regulates the temperature inside the refrigerated space of the vendor. The control is adjustable. The temperature control consist of two main parts: the temperature control box and the thermostat feeler bulb. The control box is mounted to the side of the evaporator. The bulb is mounted on the evaporator fan bracket, in the air flow of fan. The bulb is a very narrow tube with a refrigerant liquid inside. Small tubing connects the bulb to the control box. As liquid in the feeler bulb warms, it expands into the tubing and then into the control box, pressing against a bellows. The bellows closes a switch in temperature control, activating the compressor and the condenser fan. As the liquid in the feeler bulb cools it contracts and releases the pressure against the bellows, opening the switch, deactivating the compressor and the condenser fan.

START CAPACITOR - (WHEN USED)

The start capacitor is used on start up of the refrigeration system to phase out excess power to and from the refrigeration system.

STARTING RELAY

The starting relay is mounted in the terminal box on the side of the compressor housing. When the compressor first starts up, the starting relay closes and completes a starting circuit. When the compressor motor reaches operating speed, the starting relay opens and breaks the starting circuit.

THERMAL OVERLOAD SWITCH

The thermal overload switch is mounted in the terminal box on the side of the compressor housing. If the compressor motor gets hot or draws too much current, the thermal overload opens and breaks the starting and running circuit of the motor. As the motor cools, the thermal overload closes, allowing the compressor to run.



MAINTENANCE

The following section is a basic guide for general maintenance and servicing of the Vendor . This section is divided into four parts: (I) Preventative Maintenance, (II) Lubrication Guide, (III) Care and Cleaning, (IV) Basic Trouble Shooting.

I. PREVENTATIVE MAINTENANCE SUGGESTIONS:

When ever a Vendor is visited on its site, the following service should be performed. Preventative maintenance will help prevent future problems with the Vendor.

- A. Observe the Vendor and its surrounding area for any unusual indications of problems (rear on cabinet, obstructions of the air flow, dark spots on the sign face, etc.)
- B. Open the door and visually check the inside of the Vendor (water accumulation, rust marks, moisture around the edges of the inner door, etc.)
- C. Check the fluorescent lamps, replace as necessary. Replace single pin (slimline) lamps within 24 to 48 hours of burnout. This will prevent damage to ballast.
- D. Check the product temperature for proper cooling.
- E. Check evaporator drain for obstruction; water in the evaporator area must drain to the condensate pan.
- F. Empty condensate pan.
- G. Clean the condenser, free vanes of dirt, lint, etc.
- H. Check evaporator fan(s) run normally.
- I. Check the Compressor and condensate fan run normally.
- J. Investigate any unusual sounds (fan blades hitting something, refrigeration lines rattling, etc.)
- K. Clean coin acceptor.
- L. Deposit all coinage accepted by the Vendor to check for proper operation of the coinage mechanism.
- M. Test the Vendor and make a report on the problems,

II. LUBRICATION GUIDE:

Lubricate indicated areas as directed on the chart below.

INTERVALS	PARTS	LUBRICANT
Every six months	Top hinge of door door hinge pin at the base of cabinet door latch cam to cabinet strike T-handle shaft & latch.	Grade two, high low temperature grease
As necessary	Pivot area of bucket and gate	Grade two, high low temperature grease



III. CARE AND CLEANING

- A. GENERAL PROCEDURE (painted metal areas)
Wash Vendor with soap and water. The exterior may be waxed with any good automobile wax.
- B. FRESH PAINT SPLASHES, GREASE, GLAZING COMPOUND REMOVAL
Before drying, these elements may be removed by rubbing lightly with grade "A" Naptha (or equivalent grade solvent). After removal, use general cleaning procedure (listed above as A)
- C. LABELS AND STICKER REMOVAL
Use Kerosene, VM&P grade Naptha or petroleum spirits for removal. When the label material does not allow penetration of solvent (such as vinyl) the application of heat (hair blow dryer) will soften the adhesive and promote removal. **CAUTION:** Excessive heat can cause surface damage. After the label is removed, use the general cleaning procedure (listed above as A).
- D. SCRATCH REMOVAL
Remove or minimize hairline scratches and minor abrasions by using any good quality automobile polish. Test product before using.
- E. LEXAN SIGNS
To clean Lexan sign faces the following procedure is recommended.
1. Wash sign with mild soap or detergent and lukewarm water.
 2. Using soft cloth or sponge, gently wash the sign. **DO NOT SCRUB!**
 3. Rinse well with clean lukewarm water.
 4. Dry thoroughly with a chamois or cellulose sponge (to prevent water spotting). **DO NOT USE SQUEEGEE!**
- NOTE:** Most organic solvents, petroleum, spirits, or alcohol are **NOT** compatible cleaning materials for lexan signs. Usage of those materials could permanently damage the sign.
- F. REFRIGERATION AREA
The condenser and evaporator must be kept clean for efficient operation. Be sure all vanes and tubing are clean and clear of obstruction; This allows free passage of air. Clean with a brush, a vacuum cleaner or compressed air. Keep cabinet drain open; clean as necessary.



TRUBLE-SHOOTING GUIDE

This guide is a general list of probable problems, causes, and solutions. For problems not listed or additional question, contact the Field Service Department at Vendo, 7209 N. Ingram Ave., Fresno, CA 93650 or call 1-800-344-7216. Please have the manufacturer's date code and model number of the vendor when you call.

The trouble-shooting guide is divided into three columns: First Column, Possible Problem; Second Column, Possible Cause; Third Column, Service Suggestion.

POSSIBLE PROBLEMS	POSSIBLE CAUSE	SERVICE SUGGESTION
Returns all good coins	No power to vendor	Check power Supply
	No power to changer	Check coin mechanism plugs check for faulty harness wiring (see wiring diagram for circuit)
	Acceptor is out of adjustment or coin gate is not closed	Check coin mechanism
	Electronic-CREM function: 1.) No power to acceptor. 2.) Defective acceptor	1. Check electrical connections of the acceptor. 2. Replace acceptor
	Coin paths are dirty	Clean acceptor with approved cleaner. <u>DRY VERY THOROUGHLY</u>



POSSIBLE PROBLEM	POSSIBLE CAUSE	SERVICE SUGGESTION
Money accepted no product vended	No selections work	Check No.1 selection switch, replace if necessary.
	No. 1 selection works, No. 2 thru last does not.	Check No 2. section switch, replace it necessary. This pattern can continues thru last selection switch as selection circuit goes from 1 to 2 to 3. etc., to last
	Soldout Switch (of column selected) inoperative	Check switch, replace
	Motor starts, does not run	Check motor carrier switch, replace switch
Vend motor runs until two or three products are vended or vend motors run continuously.	Improper cam lobe adjustment	Check Cam for proper arrangement of cam lobes (see product set up guide)
	Motor carrier switch not making contact with cam lobe or switch	Check lever for proper lever positioning and freedom of movement
Refrigeration unit will not run at all	No power to vendor	Check power supply also check service cord connections.
	Thermostat open (temperature control)	Check thermostat (Apply insulated jumper across terminals, if compressor starts, replace thermostat)
	Temperature control bulb out of position	Check that bulb is in air flow
Compressor will not start	Overload Protector Inoperative	Check overload (apply insulated jumper across terminal, if compressor starts, replace overload)
Compressor will not start condenser fan motor running, unit cool (no power to compressor)		

POSSIBLE PROBLEM	POSSIBLE CAUSE	SERVICE SUGGESTION
Compressor will not start,	Starting relay or capacitor	Check relay or capacitor



condenser fan motor running - unit hot (power to compressor)	inoperative	replace
	Compressor inoperative	Disconnect power to vendor, remove all leads from compressor, check continuity from “common”, “start” and “run” to compressor case. If continuity shows, replace compressor. Also Check from “common to start”. (using continuity or IHMS.) If meter fails to show reading replace compressor.
Compressor starts but does not run	Will not cycle	Check overload and contact, replace overload if necessary
	Starting relay stays closed	Replace relay
	Thermostat inoperative	Check thermostat clean contacts with approved electrical cleaner. Replace thermostat if necessary
	Compressor motor problem	Check, replace
Compressor runs but cabinet temperature warm	Loss of refrigerant	Replace refrigeration unit (Note: any work of this nature done without express permission from The Vendo Company can void refrigeration unit warranty)
	Condenser fan not working	Check circuit to run motor. Replace motor. Check for obstruction of fan blade.
	Blocked or dirty condenser (refer to initial installation in the service manual)	Check condenser vanes for obstruction, lint or dirt. Clean, also check for proper air flow through refrigeration area.
	Evaporator fan not working	Check circuit to fan motor. Replace motor also check for obstruction of fan blade
	Bad inner door seal	Check for moisture on seal. Adjust inner door as necessary (see initial setup of service manual). Replace door seal.



POSSIBLE PROBLEM	POSSIBLE CAUSE	SERVICE SUGGESTION
Compressor runs, but cabinet temperature warm	Thermostat set too high	Adjust thermostat (see initial set up of service manual)
Compressor runs continuously	Thermostat inoperative	Check thermostat
Evaporator frosted over	Water at base of evaporator unit	Check for proper drainage (such as plugged drain, kinks in drain tube, etc.) check door seal
Product freezing up too cold	Thermostat set too low	Adjust thermostat (See initial set up of service manual)
	Thermostat inoperative (compressor runs continuously)	Check thermostat replace if necessary
	Thermostat feeler bulb out of position	Adjust feeler bulb (see initial set up of service manual)
Excessive noise	Fan blade bent or hitting shroud	Straighten, relocate shroud position, or remove shroud.
	Fan motor noisy	Replace if necessary
	Refrigeration base loose or bent	Tighten bolt or replace if necessary



A COMMITMENT TO SAFETY

The Vendo Company is committed to safety in every aspect of our product design. Vendo is committed to alerting every user to the possible dangers involved in improper handling or maintenance of our equipment. The servicing of any electrical or mechanical device involves **potential hazards**, both to those servicing the equipment and to users of the equipment. These hazards can arise because of improper maintenance techniques. The purpose of this manual is to alert everyone servicing Vendo equipment of potentially hazardous areas, and to provide **basic safety guidelines** for proper maintenance.

This manual contains various **warnings** that should be carefully read to minimize the risk of personal injury to service personnel. This manual also contains service information to insure that proper methods are followed to avoid damaging the vendor or making it unsafe. It is also important to understand these **warnings** are not exhaustive. Vendo could not possibly know, evaluate, or advise of all of the conceivable ways in which service might be done. Nor can Vendo predict all of the possible hazardous results. The safety precautions outlined in this manual provide the basis for an effective safety program. Use these precautions, along with the service manual, when installing or servicing the vendor.

We strongly recommend a similar commitment to safety by every servicing organization. Only **personnel properly trained** in vendor servicing **should have access to the interior of the machine**. This will minimize the potential hazards that are inherent in electrical and mechanical devices. Vendo has no control over the machine once it leaves the premises. It is the owner or lessor's responsibility to maintain the vendor in a safe condition. See Section I of this manual for proper installation procedures and refer to the appropriate service manual for recommended maintenance procedures. If you have any questions, please contact the Technical Services Department of the Vendo office nearest you. Refer to the listing at the back of this manual.

SAFETY RULES

- Read the Safety Manual before installation or service
- Test for proper grounding before installing to reduce the risk of electrical shock and fire.
- Disconnect power cord from wall outlet before servicing or clearing product jams. The vending mechanism can trap and pinch hands.
- Use only fully trained service technicians for "Power On" servicing.
- Use adequate equipment when moving a vendor.
- Always wear eye protection, and protect your hands, face, and body when working near the refrigeration system.
- Use only authorized replacement parts.
- Be aware of inherent dangers in rocking or tipping a vending machine.



SECTION I: VENDOR INSTALLATION

- A. Vendors are large, bulky machines of significant size and weight. Improper handling can result in injury. When moving a vendor, carefully plan the route to be taken and the people and equipment required to accomplish the task safely.
- B. Remove all tape, shipping sealant, and Styrofoam from the vendor. Loosen any shipping devices used to secure interior parts during shipping. Remove the wooden shipping base, attached to the vendor base by the vendor leveling screws. Make certain the leveling screws are in place and functional.
- C. Position the vendor three to four inches (7.6 cm to 10.2 cm) from a well-constructed wall (of a building or otherwise) on a flat, smooth surface.

IMPORTANT: *The vendor requires three inches (7.6 cm) of air space from the wall to ensure proper air circulation to cool the refrigeration unit.*

- D. Adjust the leveling screws to compensate for any irregularities on the floor surface. Ideally, no adjustment will be necessary and the leveling legs will be flush with the bottom of the vendor. A spirit level is a useful aid to level the vendor. When the vendor is properly leveled, the outer door, when opened, will remain stationary. Vendors must be level to assure proper operation and to maintain stability characteristics. Do not add legs to the vendor.
- E. Check the manufacturer's nameplate on the left or right side of the vendor outer door to verify the main power supply requirements of the vendor. Be sure the main power supply matches the requirements of the vendor. To ensure safe operation, plug the vendor only into a properly grounded outlet. **DO NOT USE EXTENSION CORDS.**

NOTE: Any power supply variance more than $\pm 10\%$ may cause vendor to malfunction.

- * Power outlets must be properly **grounded**.
- * Power outlets must be properly **polarized**, where applicable.

Test the outlets using the following information. (Refer to Figure 1 on Page 3.)

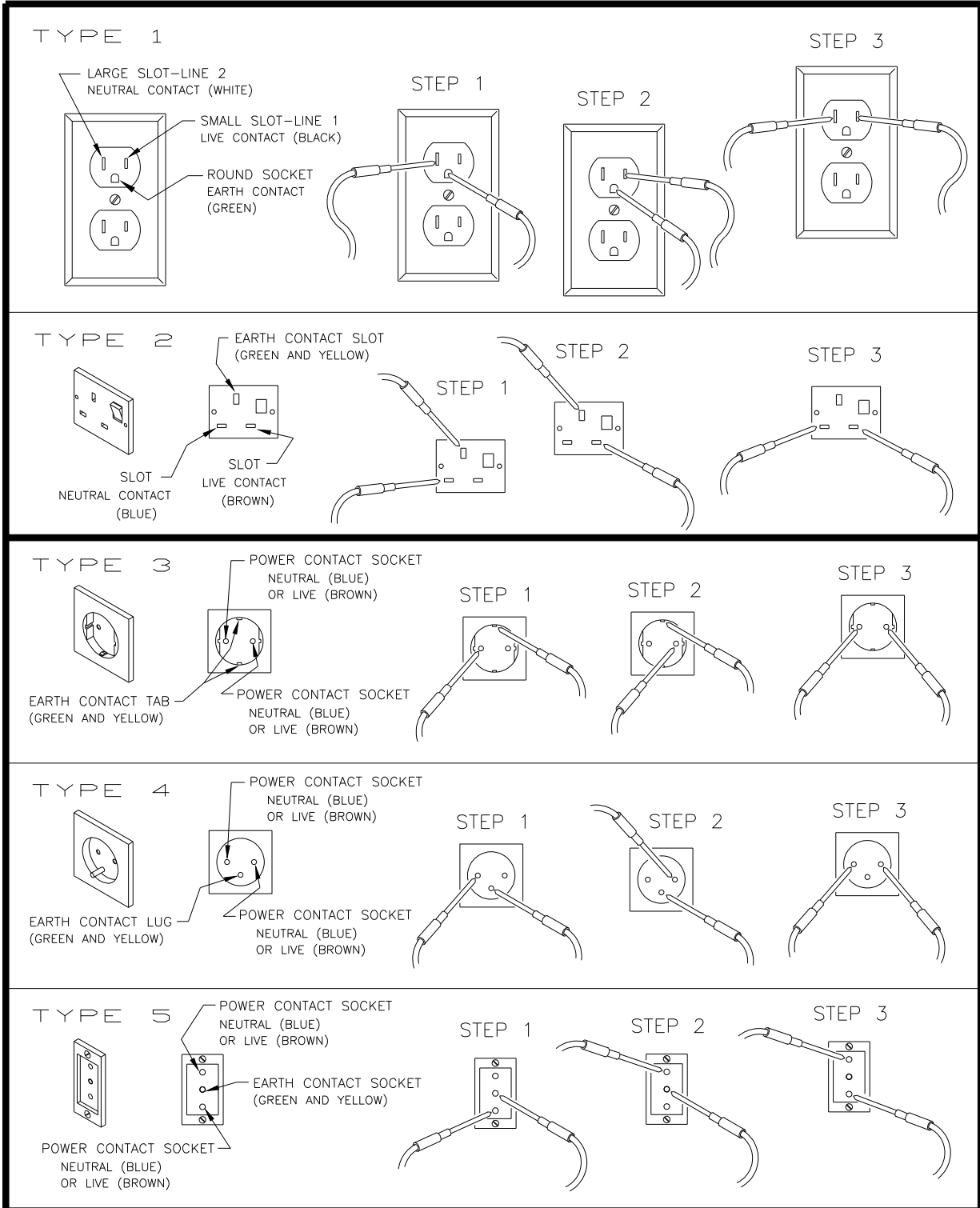

FIGURE 1



SECTION I: VENDOR INSTALLATION (CONT'D)

For Type 1 and Type 2 outlets, test for Grounding and Polarization as follows:

1. With a test device (volt meter or test light), connect one probe to the receptacle's Neutral contact and the other to the Live contact. The test device should show a reaction.
2. Connect one probe to the receptacle's Earth contact and the other to the Live contact. The test device should show a reaction.

For Type 3 through Type 5 outlets, test for Grounding as follows:

1. With a test device (volt meter or test light, determine which of the receptacle's Power contacts is the Live contact.)
 - A. Connect one probe to the receptacle's Earth contact.
 - B. Connect the second probe to the left (or upper) Power contact. If a reaction occurs, this is the Live Power contact. If a reaction does not occur, move the second probe to the right (or lower) contact. A reaction should occur, indicating that this is the Live Power contact.
2. Connect one probe to the receptacle's Live Power contact (as determined in step 1). Connect the second probe to the other Power contact (neutral). The test device should show a reaction.

**IF THE ABOVE CONDITIONS ARE NOT MET FOR THE GIVEN
OUTLET TYPE, CONTACT A LICENSED ELECTRICIAN AND
HAVE THE NECESSARY CORRECTIONS MADE.**

- F. Ambient temperature operating range for this vendor is +5°F to +113°F (-15°C to +45°C). The climatic rating of this vendor is "N" (Normal).

SECTION I: VENDOR INSTALLATION (CONT'D)

G. Door Support (Fig. 2)

The door support may be raised or lowered by adding or removing shims, to insure that the outer door closes squarely to the cabinet. Raising or lowering the door support can also insure proper alignment of the door latch.

FIGURE 2

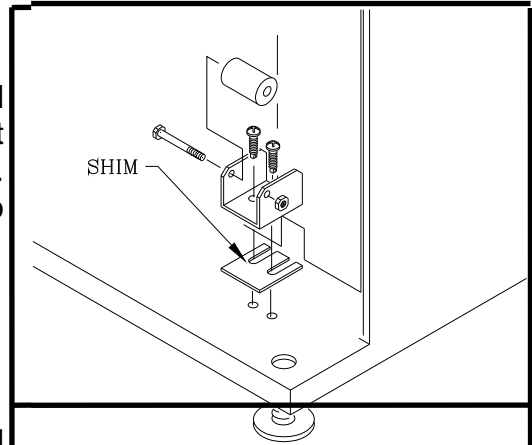

H. Door Latch Alignment (Fig. 3)

After any door adjustment, the floating Quicker Lock assembly should align itself automatically. The latch assembly is adjustable. To adjust, loosen the latch bracket mounting screws, and raise or lower the latch assembly into position, then tighten the mounting screws.

FIGURE 3

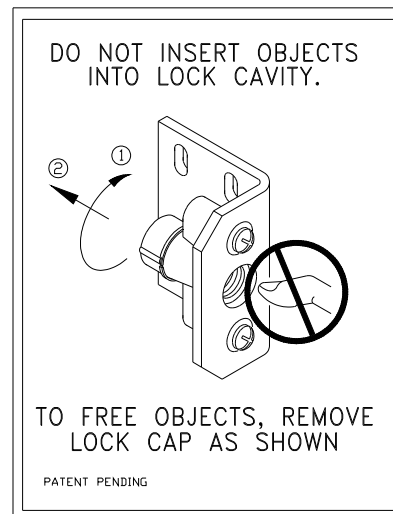
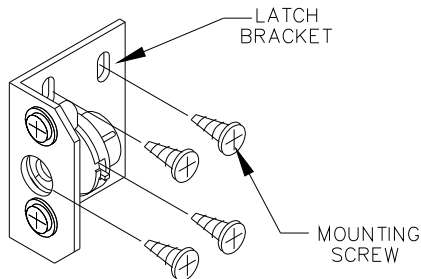

FIGURE 4

WARNING:

KEEP FINGERS AND OTHER OBJECTS OUT OF LOCK CAVITY

NOTE: Refer to the Appropriate Parts and Service Manual for Detailed Instructions, Operating Principles, and Recommended Maintenance Intervals and Procedures.



SECTION II: ELECTRICAL HAZARDS

GENERAL

Vendo vending machines are provided with the appropriate power supply setting for your area. Some models are equipped with step-down transformers, as required, enabling the vending machines to operate on different mains voltages. Refer to section I. E. for information to determine the main power requirements. Refer to the appropriate Service Manual for details of step-down transformer operation.

The power sources mentioned above are standard for both household and commercial lighting and appliances. However, careless or improper handling of electrical circuits can result in injury or death. Anyone installing, repairing, loading, opening, or otherwise servicing a vending machine should be alerted to this point. Apply all of the normal precautions observed in handling electrical circuits, such as:

- Refer servicing to qualified personnel only.
- Unplug the vendor before servicing or clearing product jams.
- Replace electrical cords if there is any evidence of fraying or other damage.
- Keep all protective covers in place.
- Plug equipment into outlets that are properly polarized (where applicable), and protected with fuses or circuit breakers.
- All electrical connections must be dry and free of moisture before applying power.

A. Grounding Systems

Vendo vending machines are provided with the appropriate service cord for the power supply in your area. The service cord will connect to the matching electrical outlet. Always ensure that the outlet to be used is properly grounded (and polarized where applicable) before plugging in the vendor. (See pages 3 and 4).

WARNING:

**ALWAYS TEST TO VERIFY PROPER GROUNDING PRIOR TO
INSTALLATION, IN ORDER TO REDUCE THE RISK OF ELECTRICAL
SHOCK AND FIRE**

The electrical grounding system also includes the bonding of all metal components within the vendor. This involves a system of bonding wires identified by green or green and yellow marking. The system uses serrated head screws, lock washers, and star washers to assure the electrical connection between parts. Maintenance of vending equipment may involve disassembly. Include the above items when reassembling, even if the vending machine may appear to function normally without them. Omitting any of these items can compromise a link in the grounding system. See the appropriate Service Manual or kit instructions for components and assembly instructions.



SECTION II: ELECTRICAL HAZARDS (CONT'D)

B. Servicing with “Power Off”

For maximum safety, unplug the service cord from the wall outlet before opening the vendor door. This will remove power from the equipment and avoid electrical and mechanical hazards. Service personnel should remain aware of possible hazards from hot components even though electrical power is off. See the appropriate sections of this manual for further information.

C. Servicing with “Power On”

Some service situations may require access with power on. Power-on servicing should be performed **only** by fully qualified service technicians. Particular caution is required in servicing assemblies that combine electrical power and mechanical movement. Sudden movement (to escape mechanical action) can result in contact with live circuits and vice versa. It is therefore doubly important to maintain maximum clearances from both moving parts and live circuits when servicing.

WARNING:

“POWER-ON” SERVICING SHOULD BE ACCOMPLISHED ONLY BY FULLY TRAINED PERSONNEL. SUCH SERVICE BY UNQUALIFIED INDIVIDUALS CAN BE DANGEROUS.

NOTE: For Power-On servicing of vendors with a **door power switch**, it is necessary to activate the switch when the outer door is open. This is accomplished by one of the following methods:

1. Straight Plunger Switch: Pull plunger forward.
2. Protected Plunger Switch: Place key (provided) in position to hold plunger inward.



SECTION III: MECHANICAL HAZARDS

A. Servicing of Moving Parts and Assemblies

When servicing assemblies involving moving parts, **use extreme caution!!** Keep fingers, hands, loose clothing, hair, tools, or any foreign material clear of entrapment.

As noted before under the Electrical Hazards section, “Power On” servicing should **only** be performed by qualified personnel. Refer to and heed the warnings noted in Electrical Hazards section. These warnings refer to the potential hazards associated with electrical power and moving parts. Always maintain maximum clearances from electrical and moving parts.

Always install protective covers and guards when reassembling equipment.

B. Product Conversions

See the Service Section of the appropriate Service Manual for stack (or module) conversion procedures. Improper installation of product shims or spacers can result in product jams.

WARNING:

ALWAYS UNPLUG OUTLET CORD BEFORE ATTEMPTING TO CLEAR PRODUCT JAMS, TO PREVENT ENTRAPMENT OF HANDS IN MECHANISM.

WARNING:

THIS VENDING MACHINE INCLUDES MECHANICAL EQUIPMENT WHICH CAN BE HAZARDOUS IF IMPROPERLY HANDLED OR SERVICED. USE CAUTION AND CONSULT THE VENDO SAFETY MANUAL AND THE VENDO SERVICE MANUAL FOR ADDITIONAL SAFETY INFORMATION

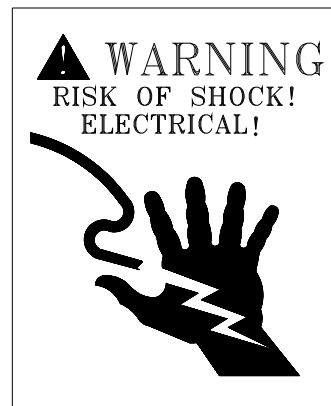



SECTION IV: REFRIGERATION HAZARDS

GENERAL

Refrigeration systems involve both electrical power and mechanical action. These systems may present any of the potential dangers shown in the sections on Electrical and Mechanical Hazards contained in this manual. See Sections II and III for further information.

A. Compressed Refrigerant

Refrigeration systems involve the compression and evaporation of gases. The pressures contained represent a potential hazard if suddenly released in confined areas. Caution is required when performing maintenance tests or repairs. All testing of sealed refrigeration systems should be done by trained personnel who are familiar with the systems and pressures involved.

B. Physical Protection

The accidental release of refrigerant gases can result in physical injuries. Always wear protective glasses and protect your hands, face, and body when working near the refrigeration system.

WARNING:

ALWAYS WEAR EYE PROTECTION AND PROTECT YOUR HANDS, FACE, AND BODY WHEN WORKING NEAR THE REFRIGERATION SYSTEM.

SECTION V: TEMPERATURE HAZARDS

GENERAL

Maintenance personnel should be alert to the potential hazards from hot metal surfaces. High temperatures may be present throughout the refrigeration system although electrical power has been removed



SECTION VI: SUBSTITUTIONS AND MODIFICATIONS

GENERAL

Unauthorized changes or the substitution of unauthorized parts can compromise the equipment designs. This can result in unsafe conditions for either the service personnel or the equipment users. Always refer to the appropriate Parts and Service Manual for replacement parts and maintenance instructions. If questions arise, contact the Technical Services Department of the Vendo office in your area. (Consult the listing at the end of this manual.)

When servicing the vending machine, always reassemble all components to their original location and position. Maintain the correct routing for tubing, electrical wiring, etc. Replace all clamps, brackets, and guides to their original locations. Replace all tubing, sleeving, insulating material, and protective covers to their original condition.

WARNING:

VENDO EQUIPMENT HAS BEEN PROVIDED WITH APPROPRIATE PROTECTIVE DEVICES TO PROTECT AGAINST THE POSSIBILITY OF OVERHEATING AND FIRE, AS A RESULT OF EQUIPMENT OR COMPONENT FAILURES. SUBSTITUTION, MODIFICATION, OR BYPASSING OF SUCH PROTECTIVE DEVICES CAN CREATE DANGEROUS CONDITIONS. PROTECTIVE CIRCUITS SHOULD NEVER BE BYPASSED, AND FAILED PROTECTIVE DEVICES MUST BE REPLACED ONLY WITH FACTORY-AUTHORIZED PARTS.

A. Service Cord Replacement

Vendo vending machines are furnished with unique power supply cords. If replacement becomes necessary, consult the appropriate Parts and Services Manual and order the correct replacement cord for the model of vending machine in question. Do not use substitute replacement cords. Only authorized service personnel with appropriate training should replace the vending machine service cord. If a question should arise concerning which service cord to order, contact the Technical Services Department of the Vendo office in your area for assistance.



SECTION VI: SUBSTITUTIONS AND MODIFICATIONS (CONT'D)

B. Service Cord Replacement (For 240 Volt System Used in the United Kingdom)

As the color of the wires in the mains lead of the vending machine may not correspond with the colored markings identifying the terminals in your plug, proceed as follows:



The wire which is colored **Green and Yellow** must be connected to the terminal in the plug which is marked with the letter **E** or by the earth symbol or colored **Green** or **Green and Yellow**.

The wire which is colored **Blue** must be connected to the terminal which is marked with the letter **N** or colored **Black**.

The wire which is colored **Brown** must be connected to the terminal which is marked with the letter **L** or colored **Red**.

Should the plug on the flexible cord not be the type for your socket outlets, do not use an adapter, but remove the plug from the cord and discard. Carefully prepare the end of the supply cord and fit a suitable plug.

WARNING:

THIS APPLIANCE MUST BE EARTHED

IMPORTANT

The wires in the mains leads are colored in accordance with the following code:

Green and Yellow	Earth
Blue	Neutral
Brown	Live



SECTION VII: CONSUMER SAFETY WARNING

WARNING:

VENDOR CAN BE OVERTURNED IF SUFFICIENT FORCE IS APPLIED, AND MAY RESULT IN SERIOUS INJURY OR DEATH.

GENERAL

There have been incidents, including fatalities, when vending machines have been vandalized by being pulled over in an attempt to obtain free product or money.

To warn of the danger involved in tipping, shaking, or rocking the vending machine, a decal has been designed to be affixed to vending machines. (One such decal is supplied with the vending machine.) Vendo will supply sufficient decals to be placed on all machines, on request. If you have any questions, contact the Vendo office in your area. (Consult the listing at the end of this manual.)

THE FOLLOWING DECAL SHOULD BE PLACED IN A POSITION ON THE VENDOR CONTROL PANEL AT EYE LEVEL.

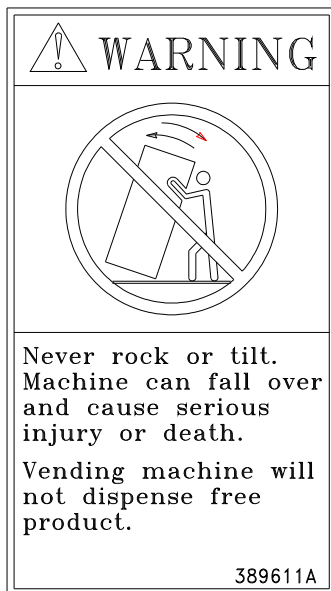

ENGLISH

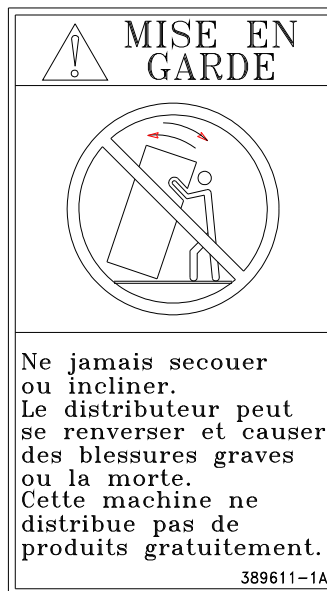

FRENCH

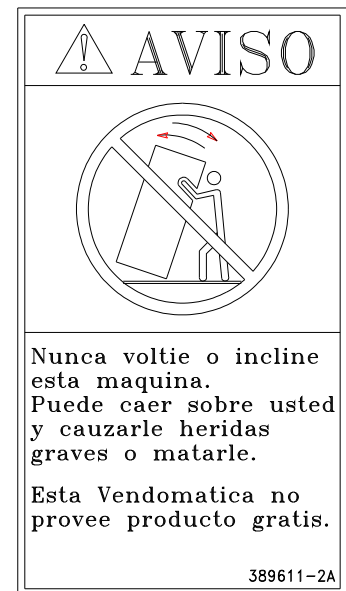

SPANISH



PARTS, SALES, & SERVICE CENTERS OF VENDO/SANDEN COMPANY

AREA	ADDRESS	PHONE NUMBERS
United States, Canada	The Vendo Company 7209 N. Ingram Fresno, CA 93650 U.S.A.	Tel: (209) 439-1770 Fax: (209) 439-2083
Japan	Sanden International Corporation 31-7 Taito 1-Chome Taito-ku Tokyo 110, Japan	Tel: (03) 3835-1321 Fax: (03) 3835-3169
Europe, Mid-East, Africa, U.S.S.R.	Vendo GMBH Spangerstr. 22 D-40599 Dusseldorf Germany	Tel: (211) 746012 Fax: (211) 7488541
Australia, New Zealand	Sanden International Pty. Ltd. 54 Allingham St., Condell Park N.S.W. 2200 Australia	Tel: 2-7910999 Fax: 2-7919029
Singapore, Hong Kong, Indonesia, Philippines, India	Sanden International (Singapore) Pte., Ltd. Sanden House, 25, Ang Mo Kio st. Y5 Singapore 2056 The Republic of Singapore	Tel: 4825500 Fax: 4825039
Taiwan	Sanden International Taiwan Corp. 7th Floor, No. 16, Alley 56, Lane 181 Sec. 4 Chunghsiao E. Rd., Taipei Taiwan, Republic of China	Tel: 2-751-2266 Fax: 2-731-3903
Belgium	N.V. Vendo Benelux, S.A. Industrial Research Park N.O.H. St. Lendriksborre 13 Font St. Landry B-1120 Brussels Belgium	Tel: (2) 2682595 Fax: (2) 2682862
England	Vendhall, Ltd. Unit 17, The Basingstoke Centre Westham Lane, Worting Rd, Basingstoke Hants RG22, 6NQ Great Britain	Tel: (01256) 479309 Fax: (01256) 844469
Italy	Vendo Italy S.p.A. Casella Postale 9 1-15033 Casale Monferrato Italy	Tel: (142) 76391 Fax: (142) 562348
Spain	Vendo Iberia, S.A. C/C Sant Ferran No. 92 Poligono Industrial la Almeda E-08940 Cornellà (Barcelona), Spain	Tel: (03) 4741555 Fax: (03) 4741842



**PARTS, SALES, & SERVICE CENTERS OF VENDO/SANDEN COMPANY
FOR LATIN AMERICA**

AREA	ADDRESS	PHONE NUMBERS
Mexico	Vendo de Mexico Camino Real de Toluca No. 154 Col. Bellavista 01140 Mexico D.F. Mexico	Tel: (525) 515-9745 Fax: (525) 277-0111
Central America	Midland Inter-American, Inc. 700 West 48th Street Kansas City, MO 64112 U.S.A.	Tel: (816) 561-5788 Fax: (816) 531-5544
Chile	Sidex San Juan 4519 - San Joaquin Santiago de Chile	Tel: (562) 553-1001 Fax: (562) 552-1982
Brazil	Cimaq Industria e Comercio de Maq, Ltda. Estrada Uniao e Industria, 9.120 Itaipava 25730-730 Petropolis Rio de Janeiro, Brazil	Tel: (55242) 22-2666 Fax: (55242) 22-3244
South America	The Vendo Company 7209 N. Ingram Ave. Fresno, CA 93650 U.S.A.	Tel: (209) 439-1770 Fax: (209) 439-2083



READING A PARTS LIST

- I **ITEM NUMBER** is found in two locations:
 - A. It is on the drawing plate, and identifies the part and its location;
 - B. The same number is in the parts lists and ties the two together.
 - II **PART NUMBER** is the part number that has been assigned to a specific part by Vendo, for easier identification.
 - III **QUANTITY REQUIRED** relates to the amount required of a part, or will be indicated by "A/R" as required to attach it to another part.
 - IV **PART NAME AND DESCRIPTION** is the general description for the part, for easier identification when ordering a like part.
-

The example below will show how the parts are listed in the parts lists:

- 1. **VEND MOTOR ASSEMBLY:** This is the main assembly named, and any replaceable parts will be indented below the assembly.
- 2. **RETAINER CAM:** This is an individual part, and will be indented. These indented parts can be ordered separately, so you do not need to order the entire assembly.
- 3. Whenever an assembly is ordered, all the parts that are indented will be included in the assembly. Any hardware will be listed next to their corresponding parts.
- 4. Any parts that may be ordered separately will not have any indented parts listed below them.

"UNIVENDOR-2" VEND MOTOR ASSEMBLY

ITEM NO.	PART NO.	QTY REQ'D	DESCRIPTION
1	133787-1	-	VEND MOTOR ASSEMBLY
2	1113244	1	RETAINER CAM
3	1113236	1	TIMING CAM
4	388687	1	CARRIER SWITCH
5	388303	1	BASE SWITCH (SPACER)
6	340025-3	1	INSULATOR
7	388637	1	VEND MOTOR
8	V384341	2	PH TAP SCREW 4- 4 x 1 1/8
9	V801422	3	HH TAP SCREW 10- 16 x 1/2

If an asterisk is listed below the parts list, it is an indication that special information is noted. There may be more than one (*) (**) (***) asterisk denoting special notes.



“UNIVENDOR-2” KIT LIST

DESCRIPTION	KIT NUMBER
INNER - OUTER DOOR LOCK	1087511
T-HANDLE LOCK COVER KIT - TRADE	1047795
T-HANDLE LOCK COVER KIT - COCA COLA	1047779
T-HANDLE LOCK COVER KIT - DR PEPPER	1051503-1
T-HANDLE LOCK COVER KIT - PC 95'	1051503-4
CROWN BOX KIT - PEPSI - TRADE	133555
CROWN BOX KIT - COKE	133555-1
VENDOR SUPPORT KIT - BLACK BRACKETS	133666
VEND DOOR BUMPER KIT	134397
WATER SHIELD KIT - COINCO ELECTRONIC	134414
BILL VALIDATOR ADAPTER KIT	133585
INNER DOOR GASKET - 72"	389622-3
INNER DOOR GASKET - 79"	389622-4
CASTER KIT	133513
CASTER W/ BRAKE KIT	133513-1
COIN BOX LOCK	1087759

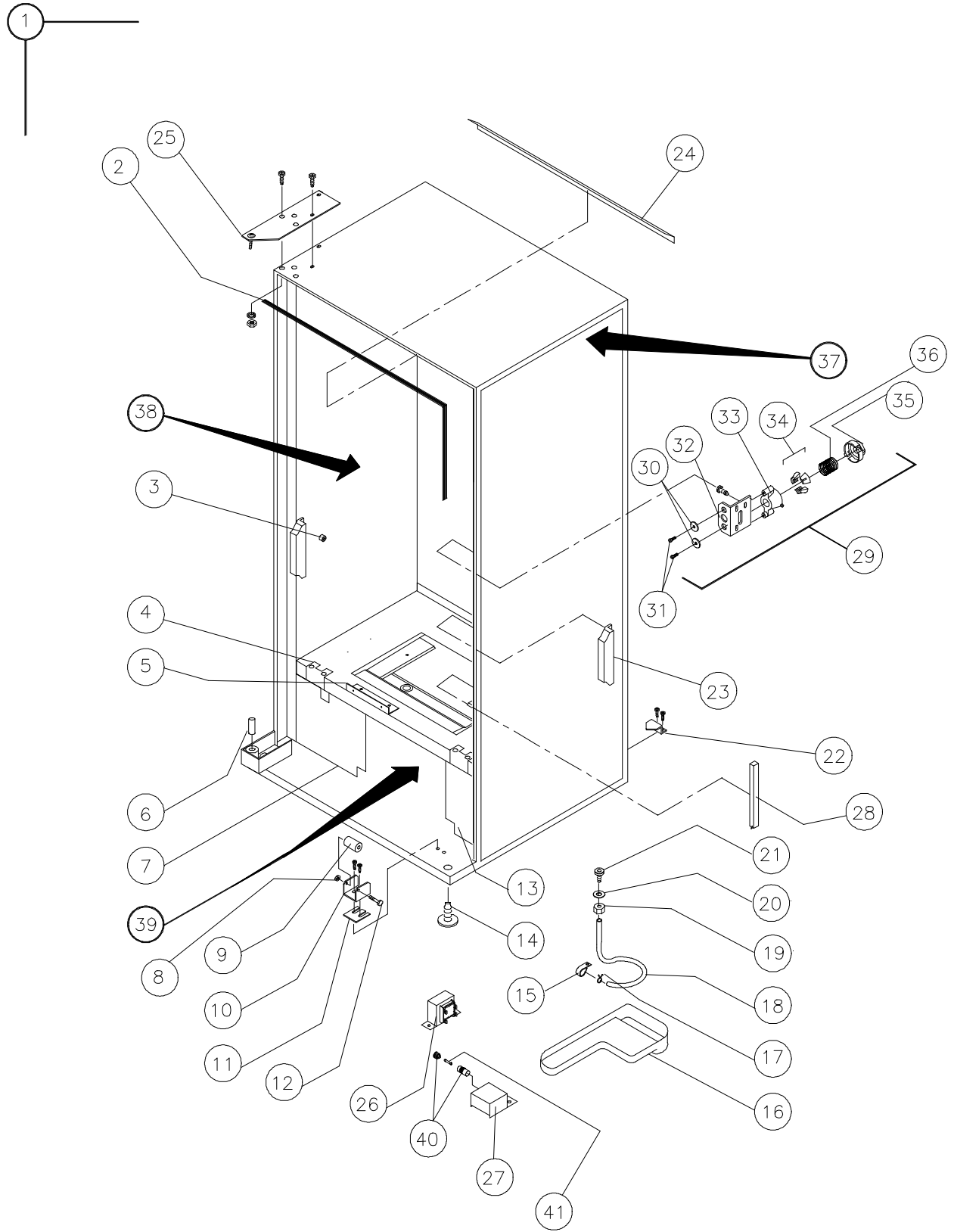



“UNIVENDOR - 2” CABINET ASSEMBLY

ITEM NO.	DESCRIPTION	REQ.	PART NO.
1*	CABINET ASSEMBLY	1	~
2	RAIN GASKET	1	389463
3	SHOULDER SCREW	2	1004328
4	CLOSURE CAP	2	388143
5	BRACKET - CHUTE	1	388387
6	HINGE PIN	1	389071
7	AIR DAM LEFT	1	1035851-1
8	1/4-20 HEX LOCK NUT	1	V802054
9	ROLLER	1	368656
10	ROLLER BRACKET - DOOR LIFT	1	388096
11	SHIM BRACKET	A/R	388097
12	1/4 - 20 x 2 1/4 HEX CAP SCREW	1	V802053
13	AIR DAM RIGHT	1	388917
14	LEVELING LEG	4	1059902
15	STRAP ADJUSTABLE - TUBING	1	342621
16	CONDENSATE PAN	1	1112023
17	CLIP - TUBING TO PAN	1	1078449
18	DRAIN TUBING	1	1111579
19	NUT - DRAIN TUBE	1	387925
20	WASHER	1	387837
21	DRAIN TUBE	1	1068678
22	BRACKET - REFRIGERATION	2	388387
23	EXTENSION INNER DOOR	2	1075309
24	AIR BAFFLE	1	1068023
25	TOP HINGE ASSEMBLY	1	2000805-03
26	TRANSFORMER (SEE PAGE B-8 OR C-10)	1	~
27	TRANSFORMER COVER (SEE PAGE B-8 OR C-10)	1	~
28	AIR BAFFLE - FOAM	2	388916
29	QUICKER - LOCK ASSEMBLY	1	1068627
30	RETAINER WASHER	2	389026
31	8-18 1/2 SCREW	2	V802044
32	LATCH BRACKET	1	2001511
33	RETAINER	1	389022
34	NUT SEGMENT	3	1033085
35	CAP	1	1111988
36	SPRING	1	389690
**37	SIDE DECAL	2	~
38	DELIVERY CHUTE - NOT SHOWN	1	1076023
39	REFRIGERATION ASSEMBLY (SEE PAGE A7 - A8)	1	~
40	FUSE HOUSING (SEE PAGE B-8 OR C-10)	1	~
41	FUSE - 5 AMP (SEE PAGE B-8 OR C-10)	1	~

*NOTE: WHEN ORDERING CABINET ASSEMBLY, PLEASE PROVIDE **9-CODE** AND **MANUFACTURER'S DATE CODE**.

NOTE: WHEN ORDERING DECALS, PLEASE PROVIDE **STYLE.

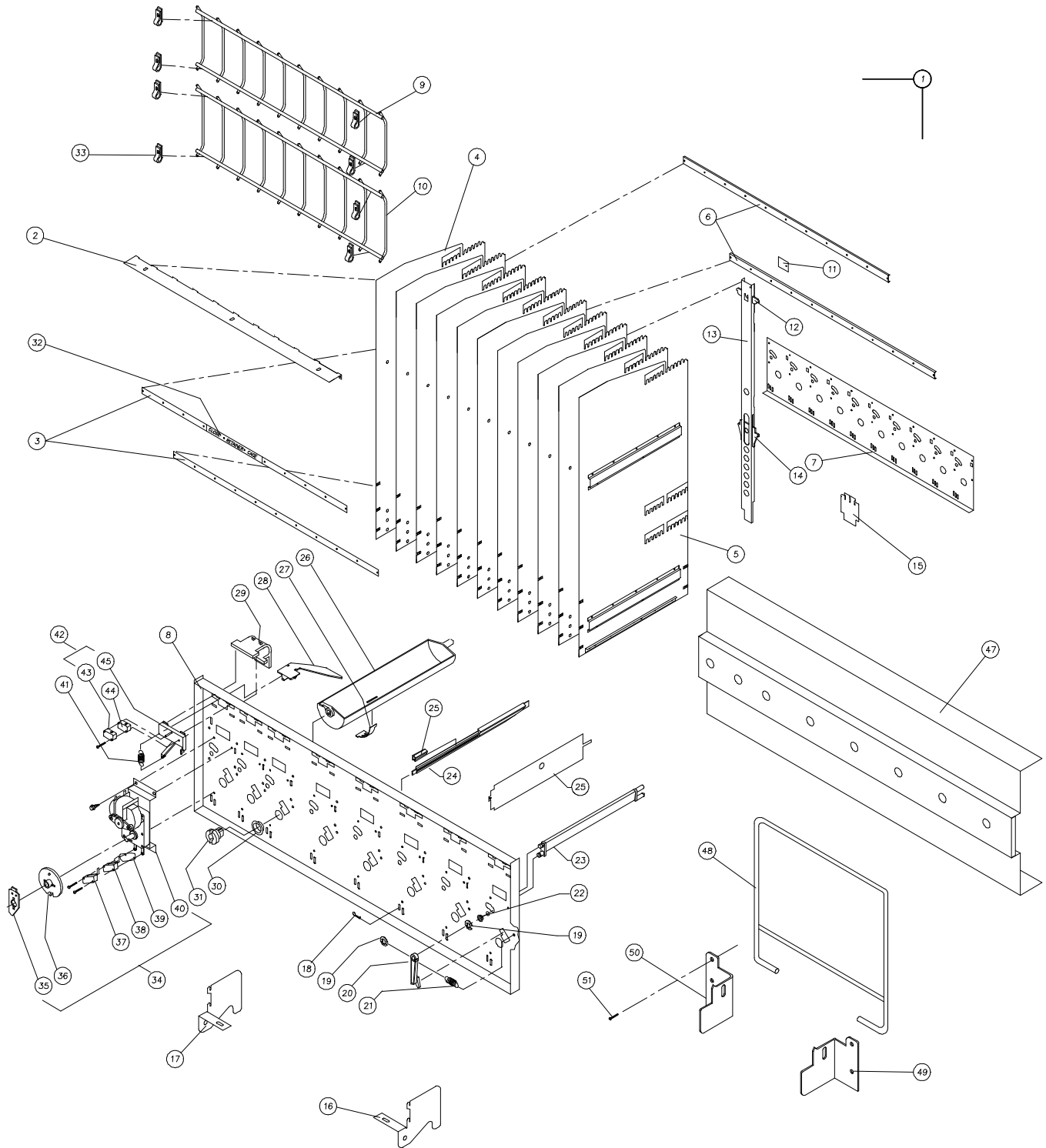



“UNIVENDOR - 2” STACK ASSEMBLY

ITEM NO.	DESCRIPTION	MODEL NUMBER		
		511	601	
NO.	DESCRIPTION	REQ.	PART NO.	PART NO.
1	VEND MECH COMPLETE	1	1069147	1069147-1
~	STACK CHASSIS	1	1037714-16	1037714-15
2	TOP SUPPORT	1	389656	389656
3	FRONT STRAP	2	389655	389655
4	PARTITION WELD ASSEMBLY L.H	10	1060325	1060325-2
5	PARTITION WELD ASSEMBLY R.H.	10	1060325-1	1060325-3
6	REAR STRAP	2	389654	389654
7	REAR MECH PLATE	1	389653	389653
8	FRONT MECH PLATE	1	1080198	1080198
9	UPPER PRODUCT CAGE ASSEMBLY	1	1080147	1080147-1
10	LOWER PRODUCT CAGE ASSEMBLY	1	1080155	1080155
11	KEEPER	10	389992	389992
12	HANGER - TOP	10	1120489	1120489
13	BACK SPACER	10	1110929	1060341-1
14	HANGER - BOTTOM	10	1120490	1120490
15	BAFFLE	10	1074015	1074015
16	PIVOT BRACKET - RIGHT	1	390363	390363
17	PIVOT BRACKET - LEFT	1	390363-1	390363-1
18	COTTER CLIP - GAGE BAR	10	387450	387450
19	E-CLIP - GATE	20	V801080	V801080
20	GATE LINK	10	1120140	1120140
21	SPRING	10	387849	387849
22	BUSHING - GATE (FRONT & REAR)	20	385603-5	385603-5
23	GATE	10	1066082	1066082
24	GAGE BAR	10	1110678	1110678
25	CLIP - SEE PRODUCT SET-UP GUIDE (TALL)	AR	1066112	1066112
~	CLIP - SEE PRODUCT SET-UP GUIDE (SHORT)	AR	1066104	1066104
~	PRODUCT SHIM - FLAT	AR	1074465	1074465
26	VEND BUCKET	10	1080236	1080236
27	ANTI THEFT CLIP	AR	389712	389712
28	SOLD OUT LEVER	10	388630	388630
~	SOLD OUT LEVER - SHORT	10	1083449	1083449
29	SPACER - SOLD OUT LEVER	10	1077457	1077457
30	BUSHING - VEND BUCKET (FRONT & REAR)	20	1008706	1008706
31	ADAPTER COUPLING	10	1076465	1076465
32	LABEL- “CLOSE RETAINER CAGE”	1	1067546	1067546
33	GLIDE CAGE SUPPORT	8	8910-0252	8910-0252
34	VEND MOTOR ASSEMBLY	10	134837-1	134837-1
35	RETAINER - CAM	1	1113244	1113244
36	TIMING CAM	1	1113236	1113236
37	CARRIER SWITCH	1	388687	388687
38	BASE SWITCH (SPACER)	1	388303	388303
39	INSULATOR	1	340025-3	340025-3
40	VEND MOTOR	1	388637	388637
41	SPRING	10	390326	390326
42	SOLDOUT LEVER ASSEMBLY	10	1069171	1069171
43	SWITCH - SOLD OUT	1	368299	368299
44	BASE SWITCH (SPACER)	1	388303	388303
45	SWITCH MOUNT - SOLDOUT	1	1005901	1005901
46	MECH HARNESS - 10 COL - (NOT SHOWN)	1	1012282	1012282
47	MECH COVER	1	1080171	1080171
48	LOADING RACK	1	134717	134717
49	BRACKET - RIGHT HAND	1	1068619-1	1068619-1
50	BRACKET - LEFTHAND	1	1068619	1068619
51	TAP SCREW 10-16 x 1/2 HEX HD CR	AR	V801422	V801422

* NOTE: DEPENDING ON PRODUCT SETUP

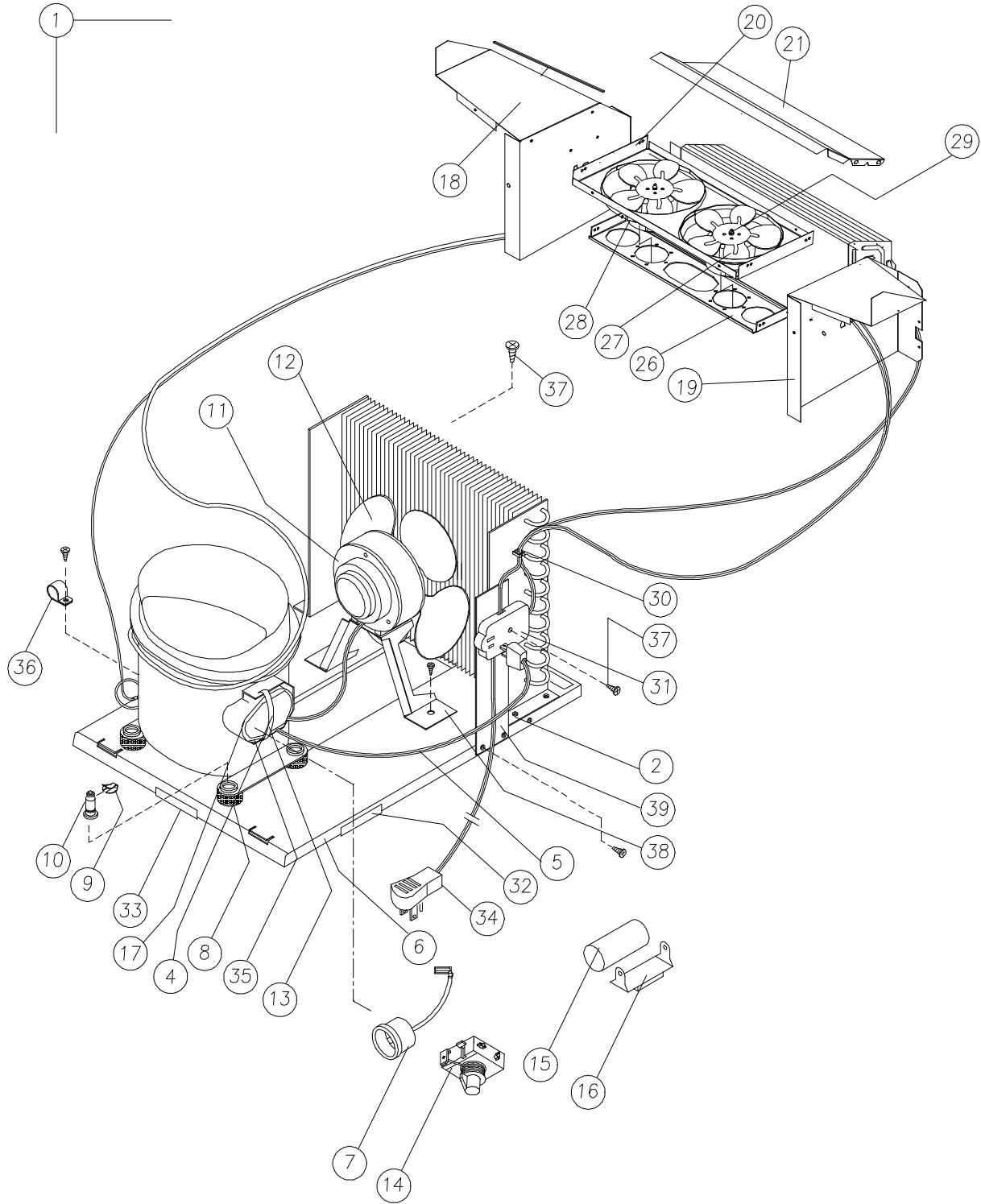



“UNIVENDOR - 2” REFRIGERATION ASSEMBLY

ITEM NO.	DESCRIPTION	REQ.	PART NO.
1	REFRIGERATION ASSEMBLY D88 TC S 1/3 R134a CAP START	1	1120341
2	TINNERMAN - CONDENSER MOUNT	2	916923
3	STRAP	1	344306
4	BRACKET - CONDENSER FAN	1	389797
5	COMPRESSOR CORD	1	1118686
6	BASE - REFRIGERATION	1	1006703
7	OVERLOAD PROTECTOR	1	45052-49
8	GROMMET - COMPRESSOR MOUNT	4	323090-1
9	CLIP - COMPRESSOR MOUNT	2	343874
10	STUD COMPRESSOR MOUNT	2	390102
11	FAN MOTOR - CONDENSER 110v	1	42321-36
12	FAN BLADE - CONDENSER	1	320766
13	COVER - OVERLOAD	1	344308
14	START RELAY 115v 60 Hz	1	333894-26
15	CAPACITOR	1	1031872
16	BRACKET - CAPACITOR	1	389617
17	SPRING - OVERLOAD	1	344305
18	RIGHT EXTENSION - EVAPORATOR	1	1067473
19	LEFT EXTENSION - EVAPORATOR	1	1067473-1
20	ORIFICE PLATE - EVAPORATOR FAN	1	360820
21	TOP COVER - EVAPORATOR	1	1067481
22	CLIP - TEMP CONTROL PROBE - NOT SHOWN	1	1030612
23	BUSHING - TEMP CONTROL PROBE - NOT SHOWN	1	389747
24	BUSHING - EVAPORATOR FAN WIRE - NOT SHOWN	1	327699-2
25	TEMPERATURE CONTROL -115v - NOT SHOWN	1	368794
26	BRACKET - EVAPORATOR FAN MOTOR	1	114589
27	FAN BLADE	2	1001272
28	EVAPORATOR FAN MOTOR 115v	2	42321-17
29	RETAINER CLIP - FAN BLADE	3	V42323
30	CLAMP - WIRE ROUTING	1	384692-3
31	BRASS NUT - CORD EYELET	2	V800892
32	EDGE TRIM - BASE (SHORT)	3	388304-1
33	EDGE TRIM - BASE (LONG)	1	388304
34	SERVICE PLUG ASSEMBLY	1	1087384
35	BALESTRAP - COVER	1	344306
36	CLAMP - DRIER	1	384692-3
37	SCREW - 10 - 32 1/2 FLAT HEAD	1	V802074
38	BRACKET - SERVICE CORD	1	390366
39	SCREW - 1/4 - 20 x 1 CR TAP	1	V801343

Vendo®

**“UNIVENDOR-2”
PARTS SECTION D
DR. PEPPER 97’
1039261D**



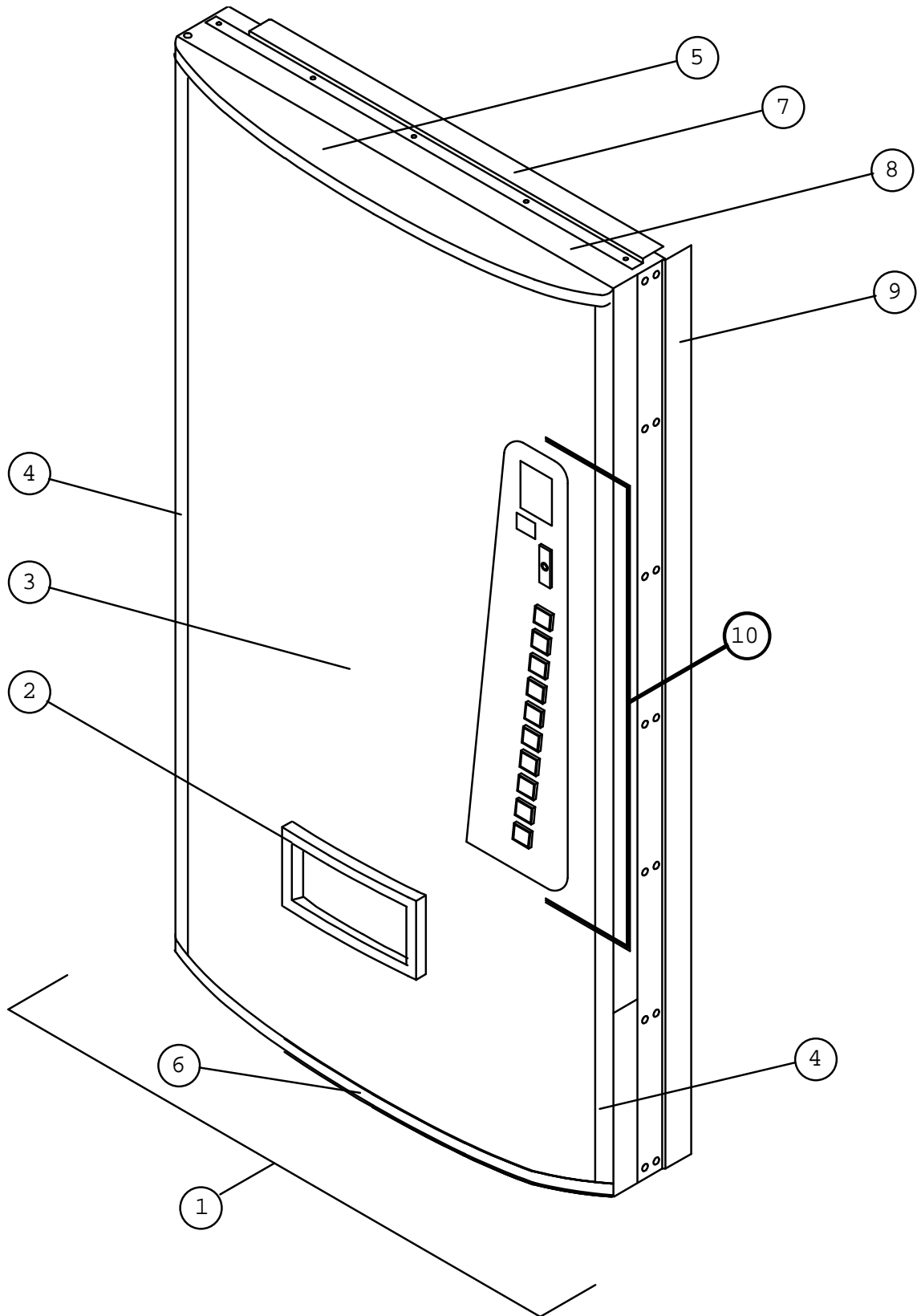

1.97



“UNIVENDOR -2” DR. PEPPER MAIN DOOR

ITEM	MODEL NUMBER	511	601
NO.	DESCRIPTION	QTY	PART NO.
1*	OUTER DOOR - 10SELECT	1	~
2	EYELET TRIM	1	388271
3**	SIGN FACE - STRAIGHT WALL BOTTLE	1	1090392-5
~	SIGN FACE - CAN ON ICE	1	1090406-10
~	SIGN FACE - PROPRIETARY BOTTLE SIGN	1	1090414-5
4	SIGN TRIM - SIDE	2	388125-2
5	SIGN CAP - TOP	1	388121
6	SIGN CAP - BOTTOM	1	1071821
7	RAIN GUARD	1	1081084
8	DOOR FRAME	1	134442-146
9	DOOR GUARD	1	1081481
10	SELECTION PANEL - SEE PAGE D5 - D8	1	~

*NOTE: WHEN ORDERING DOOR ASSEMBLY, PLEASE PROVIDE 9-CODE AND
MANUFACTURE'S DATE CODE.

NOTE: WHEN ORDERING SIGN FACE, PLEASE PROVIDE **STYLE.

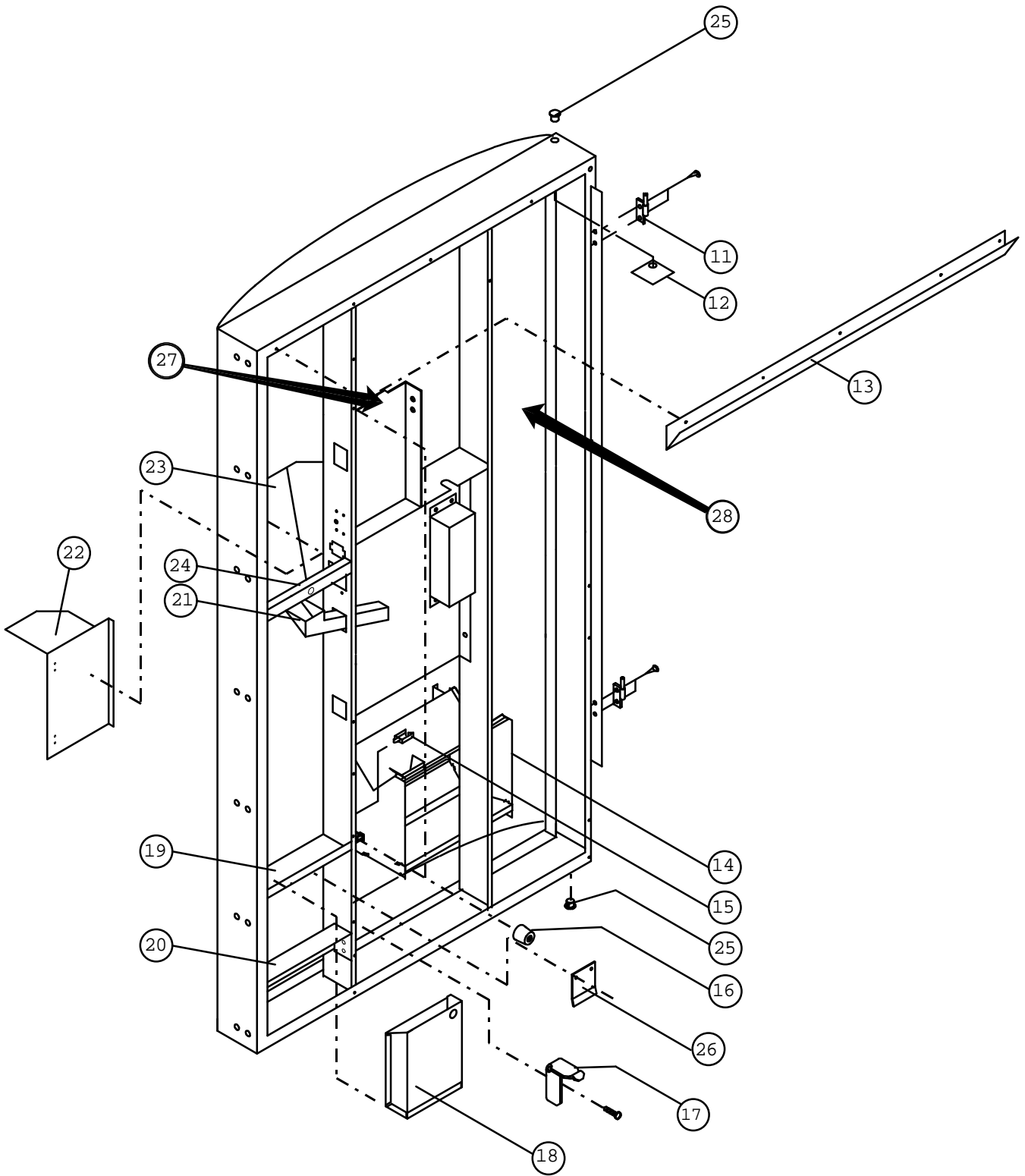

1.97

“UNIVENDOR -2” DR. PEPPER MAIN DOOR (CONTINUE)



ITEM	MODEL NUMBER	511	601	
NO.	DESCRIPTION	QTY	PART NO.	PART NO.
11	HINGE - INNER DOOR	2	388149	388149
12	BACKING PLATE	1	388443	388443
13	RAIN GUTTER	1	388581-1	388581-1
14	HOPPER ASSEMBLY	1	133574-9	133574-9
15	TIE STRAP - PUSH MOUNT	3	388359-1	388359-1
16	BUMPER - DOOR	2	1036912	1036912
17	RAMP - INNER DOOR	1	1016962	1016962
18	COIN BOX	1	134307-101	134307-101
19	SECURITY PANEL- COIN BOX	1	1083732	1083732
20	COIN BOX SHELF	1	1081589	1081589
21	COIN CHUTE ASSEMBLY	1	1081406	1081406
22	DBV COVER ASSEMBLY	1	1083805	1083805
23	SECURITY PANEL ASSEMBLY	1	1081368	1081368
24	T-HANDLE ANGLE	1	1080295	1080295
25	BUSHING	2	388094	388094
26	COIN DEFLECTOR	1	1086317	1086317
27	ELECTRONIC ASSEMBLY - SEE PAGE D9 - D10	1	~	~
28	LIGHT ASSEMBLY - SEE PAGE D13 - D14	1	~	~

*NOTE: WHEN ORDERING DOOR ASSEMBLY, PLEASE PROVIDE 9-CODE AND **MANUFACTURE'S DATE CODE.**

NOTE: WHEN ORDERING SIGN FACE, PLEASE PROVIDE **STYLE.

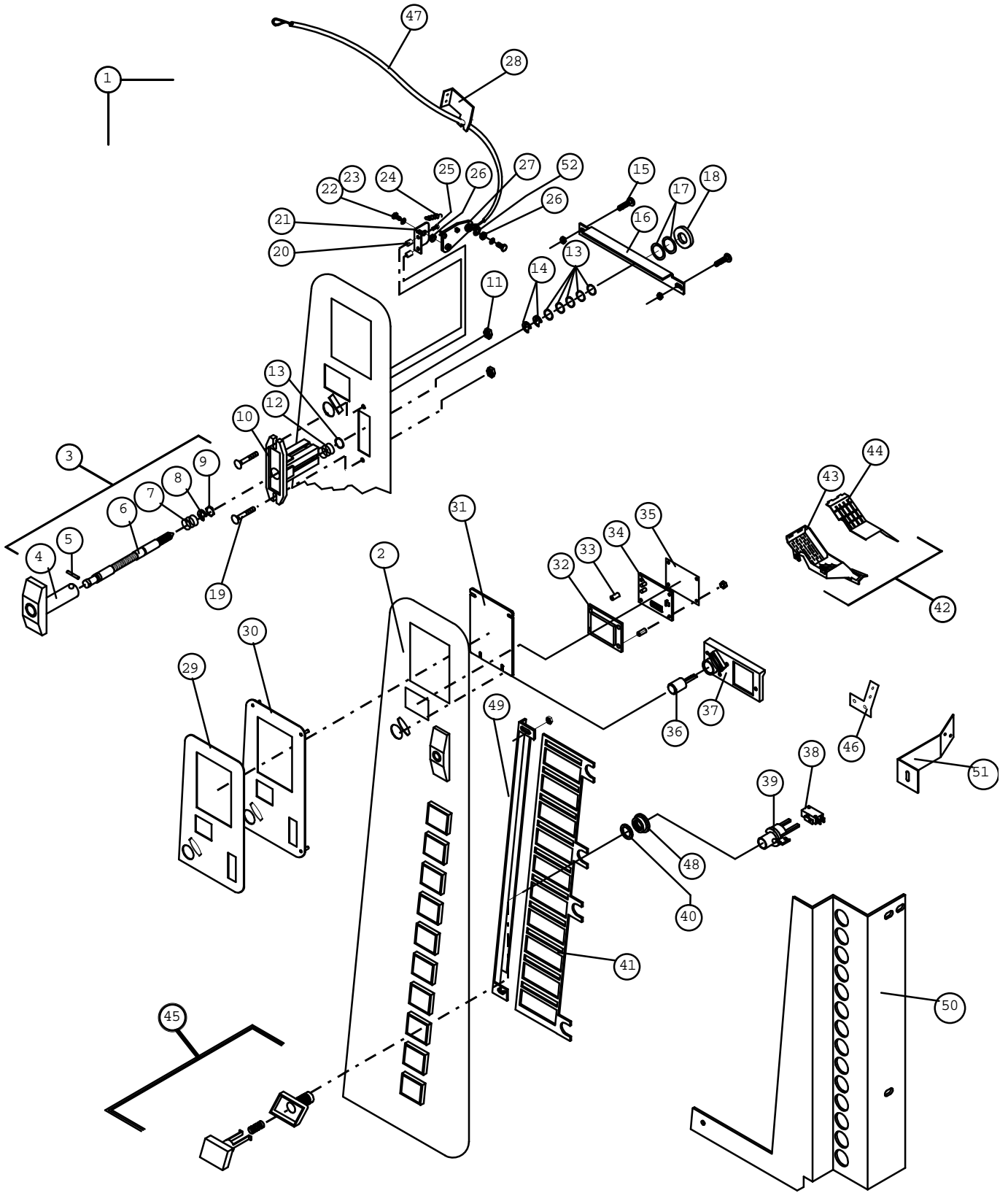



“UNIVENDOR-2” DR. PEPPER SELECTION PANEL

ITEM	MODEL NUMBER	511	601
NO.	DESCRIPTION	QTY.	PART NO.
1*	CONTROL PANEL ASSEMBLY - 10 SELECT	1	1072619-1
2**	SIGN FACE	1	~
3	LOCK ASSEMBLY	1	1080015
4	T-HANDLE	1	387603
5	PIN - STUD	1	387601
6	LOCK STUD	1	1080007
7	SPRING	1	389691
8	E-CLIP RETAINER	1	388589
9	HEX WASHER	1	387600
10	HOUSING LATCH	1	387597
11	NUT/LOCK WASHER ASSY. 1/4 - 20	AR	V800959
12	SPRING - HEAVY DUTY	1	389691
13	FLAT WASHER	6	387718
14	E-CLIP RETAINER	2	387719
15	CARRIAGE BOLT	2	V802130
16	T-HANDLE BRACKET	1	1080295
17	WASHER - 1/2"	2	V801023
18	VAPOR SEAL	1	388132
19	CARRIAGE BOLT 1/4-20 x 5/8	2	V329258-2
20	SPACER	2	1071031
21	PIVOT BRACKET - COIN RETURN	1	1081082
22	PH TAP SCREW #8-10 x 1/2	2	V801493
23	WASHER #10	1	V801013

***NOTE: WHEN ORDERING OUTER DOOR ASSEMBLY, PLEASE PROVIDE 11-CODE AND MANUFACTURER’S DATE CODE.**

****NOTE: WHEN ORDERING SIGN FACE PLEASE PROVIDE FRANCHISE AND STYLE.**

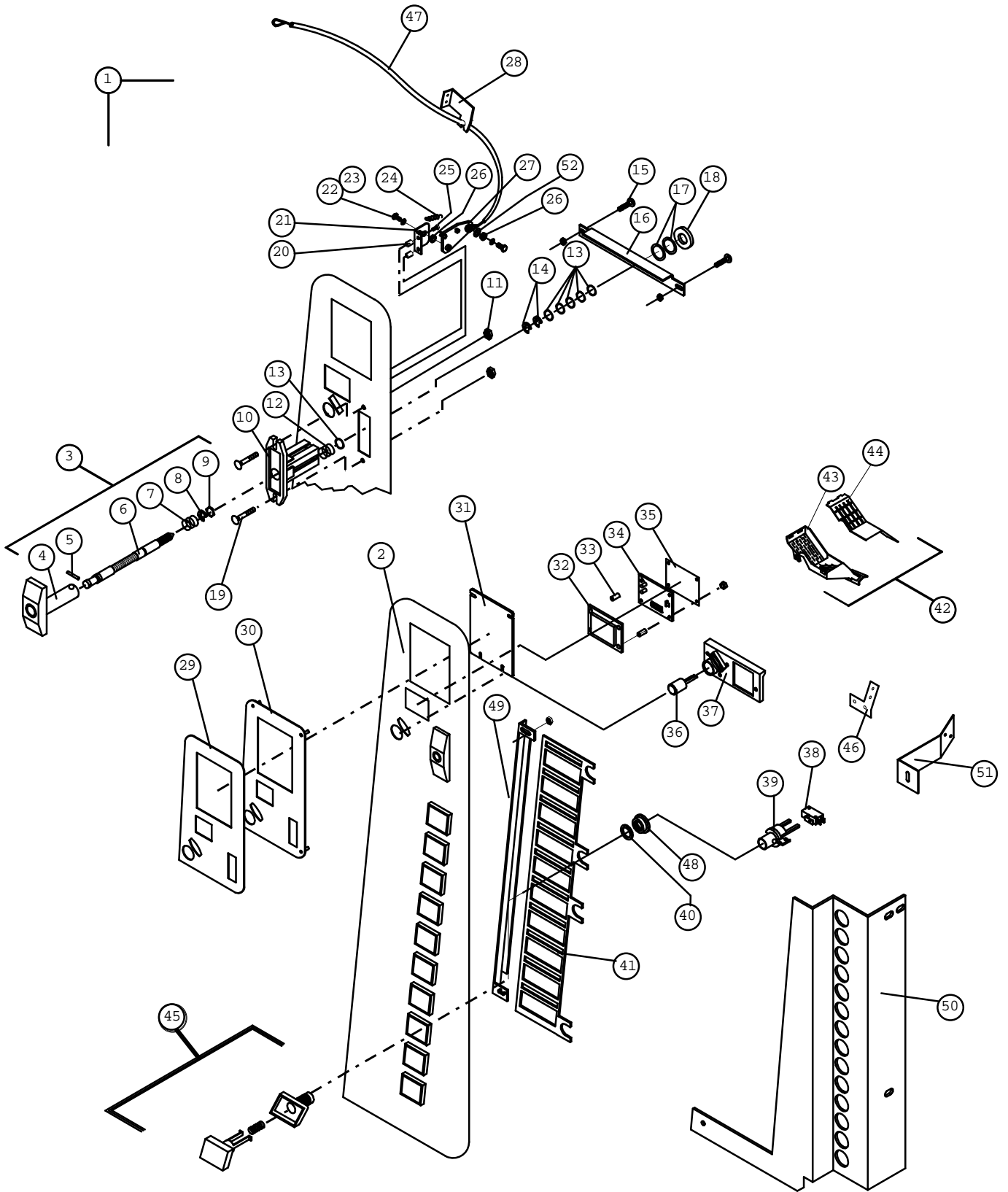



“UNIVENDOR-2” DR. PEPPER SELECTION PANEL (CONTINUE)

ITEM	MODEL NUMBER		511	601
NO.	DESCRIPTION	QTY.	PART NO.	PART NO.
24	SPRING - COIN RETURN CRANK	1	1045075	1045075
25	HH TAP SCREW #8-18 x 1/2	2	V801475	V801475
26	BUSHING	2	385603-4	385603-4
27	CRANK - COIN RETURN LEVER	1	1002244	1002244
28	BRACKET - CABLE RETURN, COIN	1	1078503	1078503
29	CONTROL PANEL - DECAL	1	1073813	1073813
30	CONTROL PANEL ASSEMBLY	1	134441-123	134441-123
31	PLUG - DBV	1	390142	390142
32	DISPLAY - LENS	1	1064155	1064155
33	SPACER	2	387238-2	387238-2
34	DISPLAY - BOARD	1	1001035	1001035
35	INSULATOR	1	1009311	1009311
36	BUTTON - COIN RETURN	1	1050473	1050473
37	COIN RETURN - GUIDE PLATE	1	1050481	1050481
38	SWITCH SELECTION	10	368299	368299
39	BUTTON SWITCH HOLDER	10	1070996	1070996
40	BUTTON WASHER	10	1073511	1073511
41	FLAVOR STRIP HOLDER	1	1073457	1073457
42	COIN CHUTE ASSEMBLY	1	1034154	1034154
43	COIN CHUTE	1	1002333	1002333
44	COVER CHUTE	1	1002341	1002341
45	BUTTON ASSEMBLY	10	1070988	1070988
46	BRACKET - CHUTE	1	1081414	1081414
47	CABLE	1	1069708	1069708
48	BUTTON NUT	10	1073538	1073538
49	FLAVOR STRIP SUPPORT	1	1075406	1075406
50	STIFFENER - BUTTON PANEL	1	1081511	1081511
51	BRACKET - BUTTON PANEL	1	1075414	1075414
52	WASHER 1" W/ .25 DIA.	1	V802128	V802128

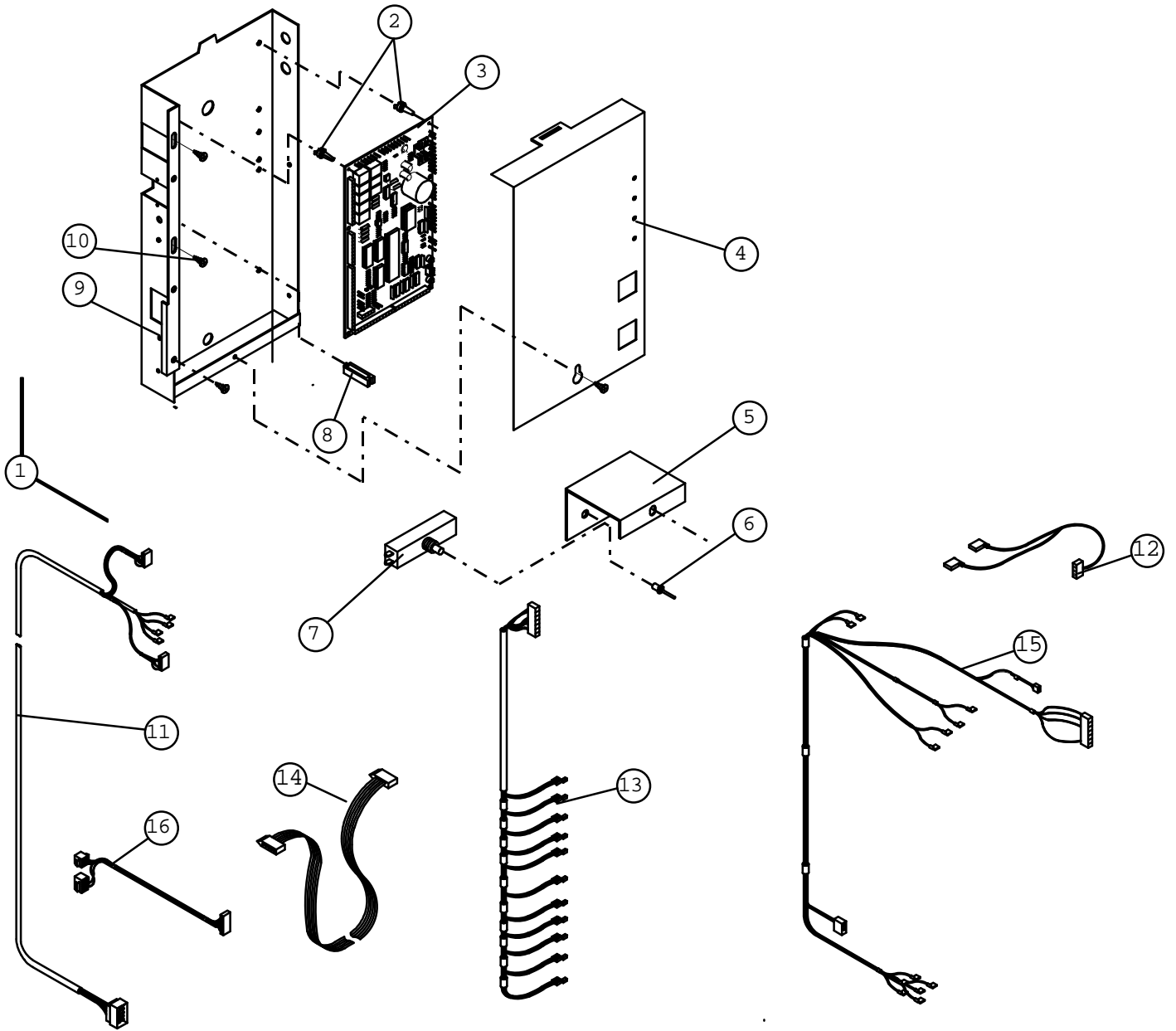



“UNIVENDOR - 2” DR. PEPPER ELECTRONIC CONTROL

ITEM NO.	DESCRIPTION	REQ.	PART NO.
1	ELECTRONIC CONTROL ASSEMBLY	1	134577-122
2	PCB STANDOFF	AR	389973
3	PCB ELECTRONIC CONTROL	1	1066236-55
4	COVER - PCB ELECTRONIC CONTROL	1	1066465
5	BRACKET - DOOR SWITCH	1	1066457
6	RIVET	2	V801412
7	DOOR SWITCH -DOMESTIC	1	323007
8	CLAMP - PUSH MOUNT	AR	384692-2
9	MOUNTING BRACKET	1	1066546
10	SCREW - 10-16 x 1/2 CR HEX SELF DRILL	AR	V801489
11	HARNESS - DOOR	1	1012304
12	HARNESS - DOOR SWITCH	1	1067503
13	HARNESS - SELECTION	1	1012312
14	HARNESS - DISPLAY	1	1001043
15	HARNESS - POWER	1	1069562
16	HARNESS - MDB	1	1070945
17	HARNESS - DEX/UCS (NOT SHOWN)	1	1013203

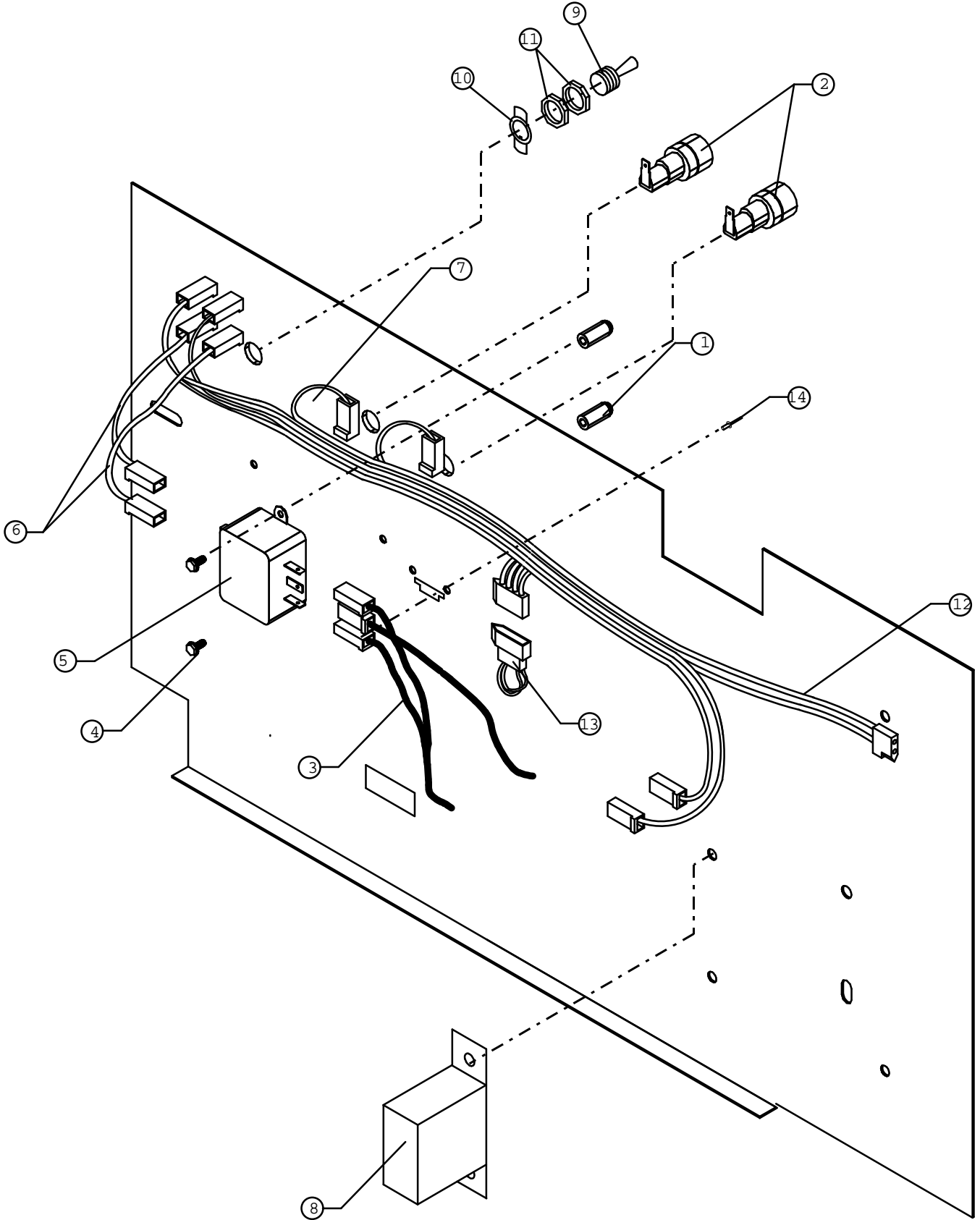



“UNIVENDOR - 2” DR. PEPPER AIR DAM ASSEMBLY

ITEM NO.	DESCRIPTION	QTY.	PART NO.
~	AIR DAM ASSEMBLY - DOM.	1	1069899
1	C.E. CAPS	2	1058198
2	FUSE HOUSING	1	387966
~	FUSE 5 AMP	1	387967
~	FUSE 0.8 AMP	1	1053864
3	HARNESS - DOOR POWER/FILTER	1	1068902
4	SELF TAPPING SCREW	2	V801489
5	LINE FILTER	1	1018302
6	HARNESS - FILTER POWER	1	1069546
7	AIR DAM - LEFT	1	1074533
8	TRANSFORMER	1	1017861
9	POWER SWITCH	1	348683
10	PLATE	1	369498
11	LOCK WASHER	2	387947
12	HARNESS - POWER TRANSFORMER VEC	1	1069503
13	JUMPER	1	1069511
14	RIVET	2	V801412

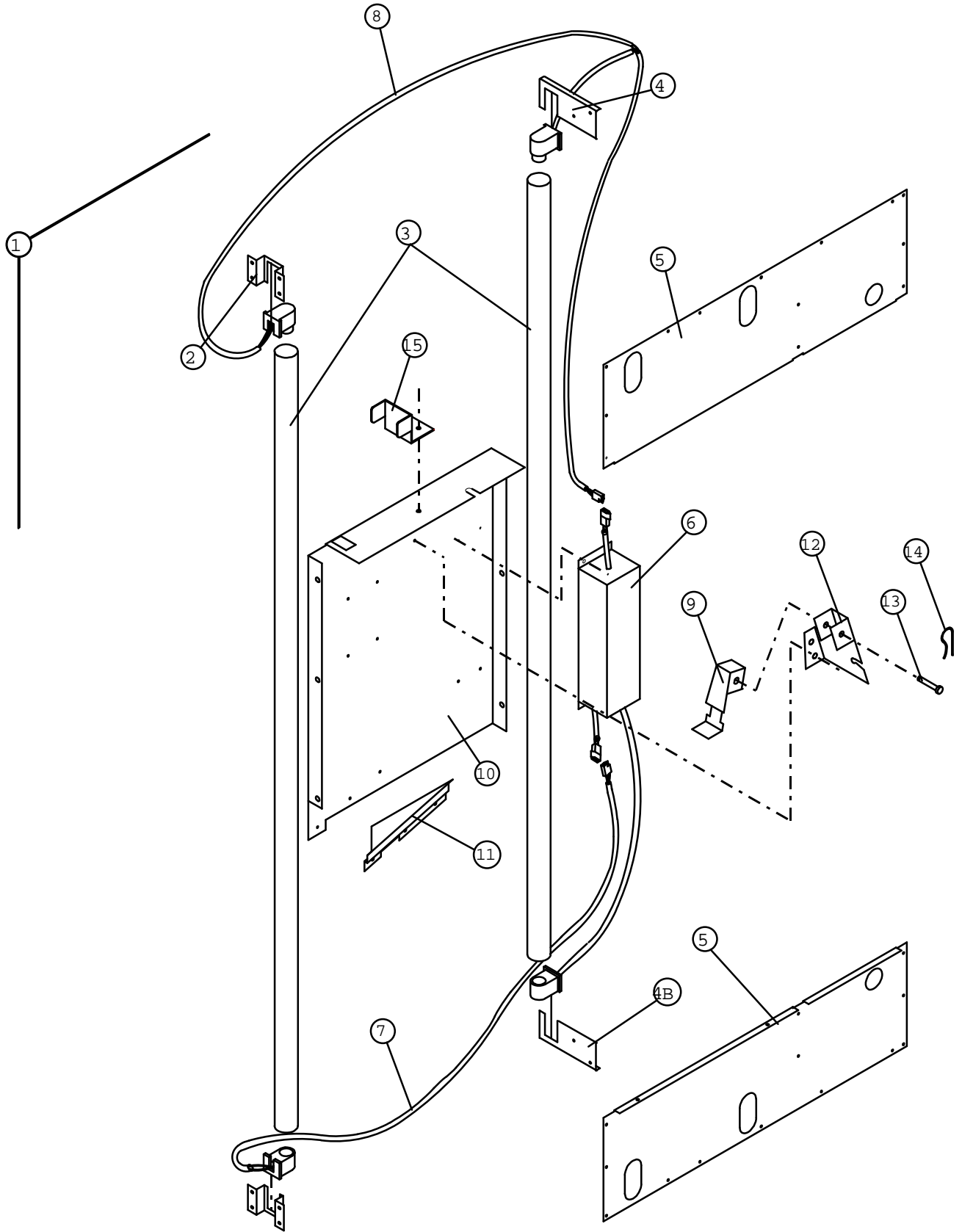



UNIVENDOR - 2" DR. PEPPER LIGHT ASSEMBLY

ITEM NO.	DESCRIPTION	QTY.	PART NO. 511	PART NO. 601
1	LIGHT ASSEMBLY	1	134308-104	134308-106
2	BRACKET - LAMPHOLDER	2	1070023	1070023
3	LAMP	2	388408-1	388408
4	MOUNTING BRACKET - LIGHTING - TOP	1	1083724	1083724
4B	MOUNTING BRACKET - LIGHTING - BOTTOM	1	1083724-1	1083724-1
5	SHEAR PANEL	2	1075481	1075481
6	BALLAST ASSEMBLY	1	1072376	1072376
7	HARNESS - LOWER LIGHTING	1	1071961	1071961
8	HARNESS - UPPER LIGHTING	1	1071988	1074333
9	COIN RETURN LEVER	1	1083759	1083759
10	MIDDLE SECURITY PANEL	1	1081473	1081473
11	COIN RETURN CHUTE	1	1078554	1078554
12	BRACKET - CABLE RETURN	1	1083775	1083775
13	PIN - CLEVIS	1	1070123	1070123
14	COTTER - PIN	1	387450	387450
15	BRACKET - ELECTRONICS BOX	1	1085449	1085449

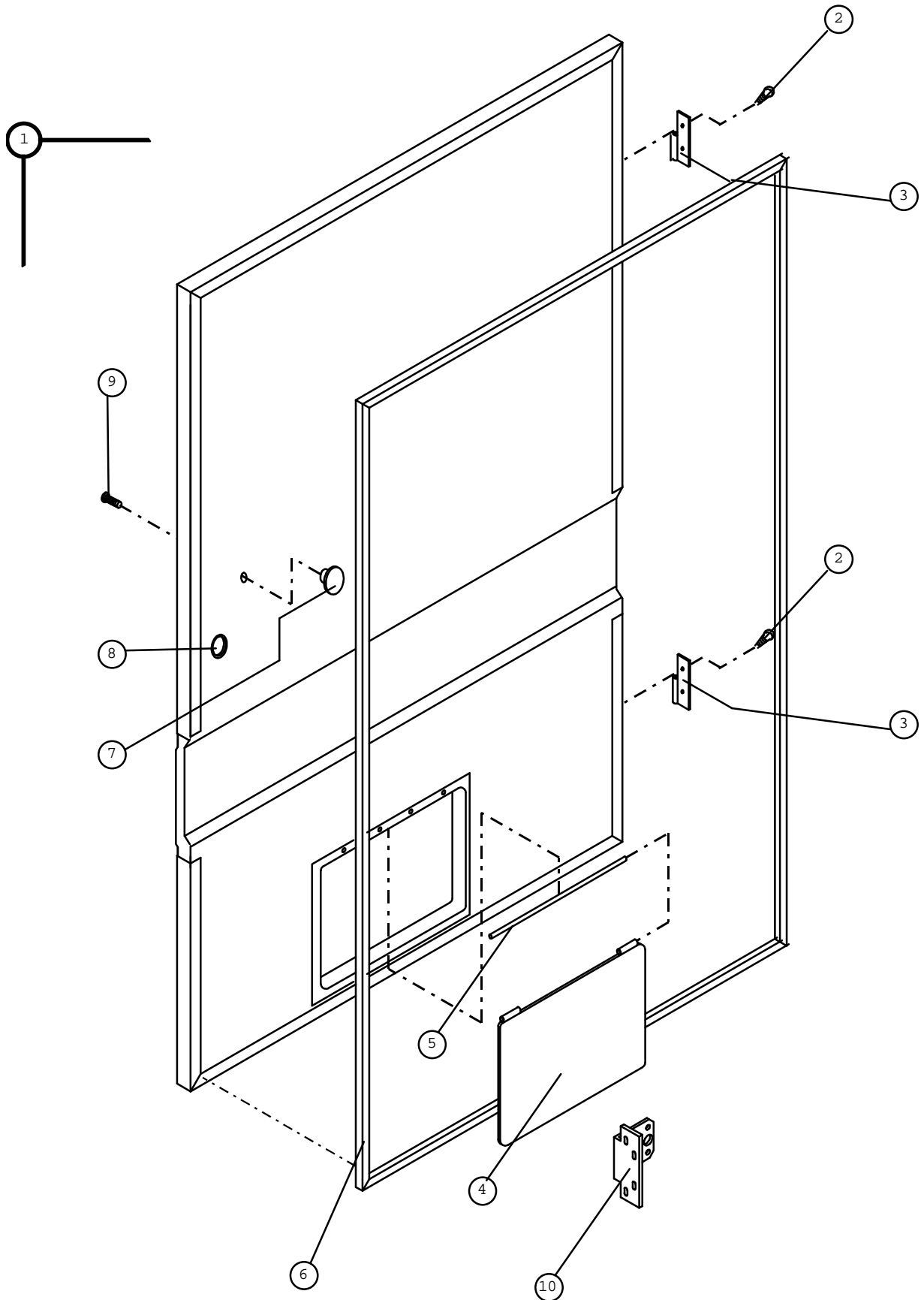



“UNIVENDOR - 2” DR. PEPPER INNER DOOR ASSEMBLY

ITEM NO.	DESCRIPTION	MODEL NUMBER	511	601
		REQ.	PART NO.	PART NO.
1	INNER DOOR ASSEMBLY (FINAL)	1	134302-37	134302-38
~	INNER DOOR ASSEMBLY (FOAMED)	1	133438-18	133438-19
2	10-16 x 1/2 HEX SCREW	6	V801422	V801422
3	HINGE - FEMALE	2	388148	388148
4	FLAP -DOOR (REVERSIBLE)	1	1013076	1013076
5	PIN - HINGE	1	389985	389985
6	GASKET - INNER DOOR	1	389622-3	389622-4
7	KNOB - INNER DOOR	1	388305	388305
8	GROMMET	2	388090	388090
9	1/4 - 20 CARRIAGE BOLT	1	V329258	V329258
10	LATCH BRACKET	1	1074708	1074708



THE VENDO COMPANY

7209 North Ingram Ave Fresno, CA 93650
Phone (800) 344-7216 - Fax (800) 541-5684

VEC 5.1-1061 - 1067 Programming Guide
DOOR OPEN CONTROL SEQUENCE
<ol style="list-style-type: none">1. Diagnostic Error Codes2. Sales Information3. Alternate Test Vend4. Control Operation & Programming

PROGRAMMING CHECKLIST
NOTICE: Do not enter the programming modes of this control without authorization and proper training.
<p>The leading cause of vendor malfunction is a control board that is not properly programmed. When installing a new board or when trying to trouble shoot a vendor that is not operating as expected, follow these steps in the order listed.</p>
<ol style="list-style-type: none">1. Space to Sales (SSS). Confirm each selection has the correct column(s) assigned. Confirm each column is assigned to at least one selection. As a starting point, assign columns to selections using the Quick Set (SSSS) Mode and pressing the last selection button (Selection 9 or 10 depending on model).2. Options (OPTS) & (OPT 2). Check the settings for each of the different options. As a starting point, set all options to factory settings.3. Price Setting (COST). Set each selection to desired price from .00 (Free Vend) to \$99.954. Timer Control (TCTL). If an optional timing device or key switch is installed, check that the selections are set as desired. (Be sure the optional timing device is operating properly.)5. When exiting "Service Modes" (i.e. actuating the door switch) you must wait 30 seconds before the vendor will accept coins or bills.

For detailed instructions, refer to the Service and Operation Manual or call the Technical Services Department of The Vendo Company at 800-344-7216 or 559-439-1770.

ERROR CODES

ERROR CODE	ACTION	TO REMOVE ERROR CODE
“NONE” No Reported Errors	No action needed	No Error Code to remove. Control board will automatically go to total historical vend.
“ER-1” Jammed Column	Press Mode Switch 1 time to identify jammed column(s)	Remove cause of motor jam and test vend all columns vended by that motor.
“ER-3” Door Left Open 1 Hour	Remove the error code and close the door	While ER-3 is displayed, press the mode switch then press and hold any selection switch for 2 seconds
“ER-4” Stuck Selection Switch	Press Mode Switch 1 time to identify stuck switch(es)	Automatically cleared when stuck switch is repaired.
“ER-5” MDB Changer Error (Valid only with MDB Interface)	Press Mode Switch 1 time to identify: “CCO” = Coin Changer Communication “TUBE” = Coin Tubes Low “ICB” = Inlet Chute Blocked	After repair, press any selection switch for 2 seconds while ER-5 is displayed.
“ER-6” MDB Coin Changer Error (Valid only with MDB Interface)	Press Mode Switch 1 time to identify: “ESC” = Excessive Escrow Attempts “JA” = Coin Jam in Changer “LO” = Low Coin Acceptance	After repair, press any selection switch for 2 seconds while ER-6 is displayed.
“ER-7” MDB Card Reader Error (Valid only with MDB Interface)	Press Mode Switch 1 time to identify: “CrOx” = Card Reader Error “Cr1x” = Invalid Card “Cr2x” = Tamper Error “Cr3x” = Manufactures Defined Error “Cr4x” = Communication Error “Cr5x” = Reader Requires Service “Cr6x” = Unassigned “Cr7x” = Manufactures Defined Error “Cr8x” = Reader Failure “Cr9x” = Communication Error-Inop Reader “CrAx” = Card Jammed “CrBx” = Manufactures Defined Error	After repair, press any selection switch for 2 seconds while ER-7 is displayed.
“ER-8”	Press Mode Switch 1 time to identify:	



STS Assignment Error (SSS)	<p>“SS_” = Unassigned Switch(es)</p> <p>“UA_” = Unassigned Column (5.1 Only)</p> <p>“DA_” = Doubly Assigned Column (5.1 Only)</p>	Automatically cleared when assignment error is corrected through SSS program mode.
<p>“ER-9”</p> <p>MDB Bill Validator Error (Valid only with MDB Interface)</p>	<p>Press Mode Switch 1 time to identify:</p> <p>“BOPN” = Bill Box Open</p> <p>“BS” = Bill Validator Sensor Error</p> <p>“BJ” = Bill Jammed</p> <p>“BILL” = Defective Motor</p> <p>“BRCH” = ROM Checksum Error</p> <p>“BFUL” = Bill Box Full (5.1 Only)</p>	After repair, press any selection switch for 2 seconds while ER-9 is displayed.

SALES INFORMATION		
DESIRED DISPLAY	ACTION FOR DESIRED DISPLAY	NEXT CONTROL ACTION
<p>TOTAL HISTORICAL VENDS</p> <p>“CANS”</p> <p>(Non-Resettable)</p>	<p>If No Errors: No action is required to display total vends</p> <p>If Error Codes are not cleared: Press selection switches 1 and 2 at the same time</p>	After 15 seconds, control will automatically go to alternate test vend operation.
<p>VENDS BY SELECTION</p> <p>(Since Last Reset)</p>	Pressing any selection button will display unit sales for that selection since the reset button was last pressed.	After 15 seconds, control will automatically go to alternate test vend operation.
<p>TOTAL HISTORICAL CASH</p> <p>“CASH”</p> <p>(Non-Resettable)</p>	<p>From Total Vends: No action is required to display total cash</p> <p>From vends by selection: Press selection switches 1 and 2 at the same time</p>	After 15 seconds, control will automatically go to alternate test vend operation.

NOTE: OPTIONAL DOOR CLOSED DATA RETRIEVAL

If desired, “**Total Historical Vends**” and “**Vends By Selection**” may also be retrieved with the door closed after entering passcode. (Refer to “OPTS”, selection 5). After passcode, vends by selection may be reset by pressing selection switches 1 And 4 at the same time and holding for 3 seconds.

ALTERNATE TEST VEND		
DISPLAY	HOW TO DISPLAY	ACTION
“.00” OR “(VEND PRICE)” (With inner and outer doors separated)	Control board automatically reverts to this display from “Sales Information” Or “Control Operation & Programming” after 15 seconds of inactivity.	All vend and cash activities effect special test meters (counters) only and will not change normal (Door Closed) vend or cash meters.

CONTROL OPERATION & PROGRAMMING SUMMARY		
MODE	OPERATION	RESULT/RESPONSE
CHANGE PAY OUT “CPO” (Press Mode Switch One Time)	Press Selection Switch 1	.05  Pay Out
	Press Selection Switch 2	.10  Pay Out
	Press Selection Switch 3	.25  Pay Out
	Press Selection Switch 4	\$1.00 Coin Pay Out (If Coin Changer is Available)
COLUMN TEST VEND “TEST” (Press Mode Switch Two Times)	Press Selection Switch 1	Increases Displayed Column Number
	Press Selection Switch 2	Decreases Displayed Column Number
	Press Selection Switch 3	Vends Displayed Column Number
PRICE SETTING “COST” (Press Mode Switch Three Times)	Press Any Selection Switch	Selection’s Current Price Is Displayed
	Press And Hold Same Selection	Selection’s Price Increases
	Press And Hold Same Selection	Selection’s Price Decreases

CONTROL OPERATION & PROGRAMMING SUMMARY

MODE	OPERATION	RESULT/RESPONSE
OPTIONS "OPTS" (Press Mode Switch Four Times)	Bill Handling Press Selection Switch #1 (Continue to press #1 until desired setting is reached.)	Bill Handling 1 = Force Vend if bill is accepted. Scavenger lever will return change. 2 = Change Machine 3 = Bill accepted is held in escrow. Scavenger lever will return bill.
	Correct Change Acceptance Press Selection Switch #2 (Continue to press #2 until desired setting is reached.)	Correct Change Vending 1 = Only correct change accepted for vend 2 = Correct change or greater accepted for vend 3 = Same as #1 Special Application Only 4 = Same as #2 Special Application Only
	Zero Indicator Press selection switch #3 (Continue to press #3 until desired setting is reached.)	"o" in Display to Indicate Sold Out or Jammed Column(s) 1 = On 2 = Off
	Fast Price Set Press selection switch #4 (Continue to press #4 until desired setting is reached.)	Fast Price Set 1 = Each selection's price set individually 2 = All selections same price as selection 1's price
	Door Closed Data Press selection switch #5 (Continue to press #5 until desired setting is reached.)	Door Closed Sales Data Retrieval 1 = Off 2 = On (After 5 seconds, displays passcode)
	Control Board Identification Press selection switch #6	Displays control board ID and software revision level (Example: "1 5.1 1061")

CONTROL OPERATION & PROGRAMMING SUMMARY

MODE	OPERATION	RESULT/RESPONSE
<p>OPTIONS TWO "OPT 2" (Press Mode Switch Five Times) Options 2 Is Used Only On Models With VEC 5.1-1061. All Settings Should Remain At Factory Unless Special Applications Apply.</p>	<p>Acceptance Non-Tube Coins <i>(Special application Only)</i> Press selection switch #1 (Continue to press #1 until desired setting is reached.)</p>	<p>Acceptance of Non-Tube Coins 5 = Must have adequate change for existing credit, value of Non-Tube coin, and for all possible selections. (Factory Setting, USA) 6 = Must have adequate change for existing credit and value of Non-Tube coin (International)</p>
	<p>Multi-Vend Option <i>(Special Application Only)</i> Press selection switch #2 (Continue to press #2 until desired setting is reached.)</p>	<p>Allows Single Or Multiple Vends From One Purchase 5 =Does not allow multiple vends. (Factory Setting) 6 = Allows multiple vends.</p>
	<p>Product Count Press selection switch #3 (Continue to press #3 until desired setting is reached.)</p>	<p>Product count displays history of product vended. 5 = Count shows vends per selection. (Factory Setting) 6 = Count shows vends per price.</p>
	<p>Change Pay-Out <i>(Special Application Only)</i> Press selection switch #4 (Continue to press #4 until desired setting is reached.)</p>	<p>Change paid out when money is accepted. 5 = Yes, pay out change after selection is made.(Factory Setting) 6 = No, remaining credit will be erased after selection is made.</p>

CONTROL OPERATION & PROGRAMMING SUMMARY

MODE	OPERATION	RESULT/RESPONSE
SPACE TO SALES "SSS"	TO DISPLAY CURRENT COLUMN TO SELECTION CONNECTIONS:	
	Press and release any selection	Displays current column(s) connected to that selection
(Press Mode Switch Six Times)	TO CONNECT AND DISCONNECT COLUMNS FOR A SELECTION:	
	Press and release the selection to be changed. Then press and hold same selection again for 3 seconds	Display shows "CO 1" (Column 1). Displayed column number may or may not flash. Flashing = Column is connected to the selection Continuous = Column is not connected to the selection
	Selection Buttons 1,2, 3 and 4 are now used as programming buttons to connect and disconnect columns.	
	Press (Selection) Switch 1	Increases displayed column number
	Press (Selection) Switch 2	Decreases displayed column number
	Press (Selection) Switch 3	Changes connection status of displayed column number
	Press (Selection) Switch 4	Records and ends connection changes for the selection. Display returns to SSS beginning.
	<i>Buttons 1,2,3 and 4 are used as selection switches again. After connection changes are made and door is closed, the new settings will be displayed.</i>	

CONTROL OPERATION & PROGRAMMING SUMMARY

MODE	PREPROGRAMMED SPACE-TO SALES CONFIGURATIONS										
QUICK SET SSS “SSSS” (Press Mode Switch Six Times to Display SSS. Then Press Reset Button Twice.)	SETTING	10	9	8	7	6	5	4	3	2	1
	SEL #	COL	COL	COL	COL	COL	COL	COL	COL	COL	COL
	1	1	1,2	1	1,2	1	1	---	---	1	1
	2	2	3	2	3	2	2	---	---	---	2
	3	3	4	3	4	3	3	---	---	---	3
	4	4	5	4	5	4	4	---	---	---	4
	5	5	6	5	6	5	5	---	---	---	5
	6	6	7	6	7	6	---	---	---	---	6
	7	7	8	7	8	---	---	---	---	---	7
	8	8	9	8	---	---	---	---	---	---	---
	9	9	10	---	---	---	---	---	---	---	---
10	10	---	---	---	---	---	---	---	---	---	

After “SSSS ” is displayed, selection switches 1-10 are used to obtain desired settings. The most commonly used setting can be obtained by using the last selection switch.

TIMER CONTROL “TCTL” (Press Mode Switch Seven Times)	<i>NOTE: This mode has no meaning or effect for vendors as produced. This mode is effective only when an optional timer or key switch device is installed.</i>	
Press any selection switch	Displays Selection’s Current Setting Yes = Always vends regardless of timer No = Vending controlled by timer operation	
Press Same Selection	Changes Selection’s Setting <i>(Factory Setting = All Selections Set to No)</i>	

For detailed instructions refer to the Service & Operation Manual or you may call the Technical Services Department of The Vendo Company at 800-344-7216 or 559-439-1770.

Vendo®

VENDO WARRANTY

NEW EQUIPMENT

- I. This is Limited Warranty.
- II. The Vendo Company warrants, to the original purchaser, each part of each new vending machine for a period of fifteen (15) months from the date of shipment, to be free from defects in material and workmanship. This Warranty DOES NOT include light bulbs, fluorescent tubes, fuses, finish, or operating supplies.
- III. In addition to the fifteen (15) month's Warranty on each part of each new vending machine, the hermetically-sealed refrigeration system used in machines designed to vend bottles, cans, and aseptic cartons is warranted to be free from defects in materials and workmanship for an additional four (4) years, provided the hermetically-sealed portion of the system has not been opened or damaged. Hermetically-sealed refrigeration systems DOES NOT include fan motors temperature controls, capacitors, overload switches or starting relays which are covered by the fifteen (15) month Warranty.
- IV. Electronic control board and the LED display are warranted against defects in material and workmanship for an additional two (2) years. The Company, at its option, will either repair or replace products that prove to be defective.
- V. To qualify for Warranty replacement, all requests for returns must be made in writing within the warranty period, accompanied by a record of the cabinet model and serial number. If a return is found to be inoperative due to defects in material and/or workmanship, we will at our option make necessary repairs or furnish a reconditioned or new replacement part or refrigeration system at no charge.
- VI. The Vendo Company will pay normal transportation charges on parts and refrigeration system replaced under this Warranty. If special handling or premium transportation is requested, these charges are assumed by the purchaser.
- VII. Any parts and/or refrigeration systems replaced during the warranty period are warranted for the remaining time on the original warranty.
- VIII. This Warranty DOES NOT apply to machines located outside the United States and Canada reconditioned equipment, equipment sold "as is", or components designed to work on electric current other than 110/120 60 cycle or 208/220 50 cycle, as specified on the serial tag.
- IX. Title and risk of loss pass to the purchaser on delivery of the vending machine, replacement part and/or refrigeration system to the common carrier. All loss and damage claims are the responsibility of the purchaser and must be filed with the delivering carrier.
- X. This Warranty DOES NOT include any service guarantee, either explicit or implied, nor will it extend to cover incidental or consequential damages or damages resulting from purchaser or third party negligence, accident, vandalism or an act of God.
- XI. The Vendo Company reserves the right to make design changes, addition to, and improvement upon any of our product without incurring any obligation to incorporate same on any product previously manufactured.
- XII. This Warranty is in lieu of all other express warranties or other obligations or liabilities on our part, and we neither assume nor authorize any person to assume for us, any other obligation for liability in connection with the sale of said machines or parts thereof. **EXCEPT AS SPECIFICALLY PROVIDED HEREIN, THERE ARE NO WARRANTIES GIVEN, EITHER EXPRESS OR IMPLIED, AND ALL OTHER WARRANTIES, INCLUDING SPECIFICALLY BUT WITHOUT LIMITATION WARRANTIES OF MERCHANTABILITY AND FITNESS FOR PARTICULAR PURPOSE, ARE HEREBY EXPRESSLY DISCLAIMED**

THE VENDO COMPANY
2/1996